

**Geometric Curve Drawing Devices as an
Alternative Approach to Analytic
Geometry:
An Analysis of the Methods, Voice, and
Epistemology of a High School Senior**

David Dennis

&

Jere Confrey

Mailing Address:

Dr. David Dennis

4249 Cedar Dr.

San Bernardino, CA 92407

e-mail: david.dennis@earthlink.net

Tel: 909-883-0848

Published in R. Lehrer and D. Chazan (Eds.)
Designing Learning Environments for Developing Understanding of Geometry and Space.
Hillsdale, NJ: Lawrence Erlbaum Associates, 1998.

This research was funded by a grant from the National Science Foundation.
(Grant #9053590)
The views and opinions expressed are those of the authors and not necessarily those of
the Foundation.

Geometric Curve-drawing Devices as an Alternative Approach to Analytic Geometry: An Analysis of the Methods, Voice, and Epistemology of a High School Senior

David Dennis & Jere Confrey

Part 1 - Introduction

When the concept of analytic geometry evolved in the mathematics of seventeenth century Europe, the meaning of the term was quite different from our modern notion. The main conceptual difference was that curves were thought of as having a primary existence apart from any analysis of their numeric or algebraic properties. Equations did not create curves; curves gave rise to equations. When Descartes published his *Geometry* in 1638 (Trans. 1952), he derived for the first time the algebraic equations of many curves, but never once did he create a curve by plotting points from an equation. Geometrical methods for drawing each curve were always given first, and then, by analyzing the geometrical actions involved in a physical curve-drawing apparatus, he would arrive at an equation that related pairs of coordinates (Dennis, 1995; Dennis & Confrey 1995). Descartes used equations to create a taxonomy of curves (Lenoir, 1979).

This tradition of seeing curves as the result of geometrical actions continued in the work of Roberval, Pascal, Newton, and Leibniz. As analytic geometry evolved towards calculus, a mathematics developed that involved going back and forth between curves and equations. Operating within an epistemology of multiple representations entailed a constant checking back and forth between curve generating geometrical actions and algebraic language (Confrey & Smith, 1991). Mechanical devices for drawing curves played a fundamental, coequal role in creating new symbolic languages (e.g., calculus), and establishing their viability. The tangents, areas and arc lengths associated with many curves were known before any algebraic equations were written. Critical experiments using curves allowed for the coordination of algebraic representations with independently established results from geometry (Dennis, 1995).

What we present here is a description of one student's investigation of two curve-drawing devices. The usual approach to analytic geometry where a student studies the graphs of equations has been reversed, in that the student primarily confronts curves created without any preexisting coordinate system. This student first physically establishes certain properties of, and interrelationships between curves, and only afterward comes to represent these beliefs using the language of symbolic algebra. This student's actions are interpreted within Confrey's (1993, 1994) framework, which views mathematics as dialogue between "grounded activity" and "systematic inquiry."

In this study we provide curve-drawing devices and pose problems that allow the student an opportunity to voice both sides of this dialogue.

Part 2- The Structure of the Interviews

The purpose of the investigation is first to create a set of physical tools and then to use that environment to ask a series of questions in a setting where direct physical experiments with curves can shape a student's initial beliefs. The student is asked about how (if possible) each device can be set up to reproduce curves drawn by the other, and how he can be sure that the curves are the same. He is also asked how the action of each device might give rise to an equation of the curve. At no time, however, does the interviewer suggest the use of any particular coordinate system, origin, axes, or unit of measure.

The student is asked to justify his assertions in any way that seemed convincing to him and with as much detail as possible. From his own hypotheses, formed directly from his experience with primary curve-drawing actions, he moves, in different ways, to represent geometric actions with algebraic relations. The ways in which he describes his sense of the geometric actions strongly shapes the kind of algebraic language that he employs.

The student is given no prior instruction in the historical, cultural or mathematical significance of the devices with which he works. We teach the student rudimentary operations with each device and then pose questions about what kinds of curves each device could draw, the possible situations where different devices might or might not draw the same curve, and how the action of each device might give rise to an algebraic representation. He justifies his answers in any way that seemed appropriate.

The student investigates several curve-drawing devices, but we will discuss here only his investigation of the two elliptic devices shown in Figures 1, 2, and 3. These figures are taken from a popular seventeenth century text by Franz van Schooten (1657), who wrote extensive commentaries on Descartes. Figure 1 shows a well-known device where a loop of string is placed over two tacks. Figures 2 and 3 show what is known as a "trammel" device, where two fixed points on a stick (the trammel) move along a pair of perpendicular lines and a curve is traced by any point on the trammel, either between the two pins as in Figure 2, or outside them as in Figure 3. We built easily adjustable versions of these devices for use by students.

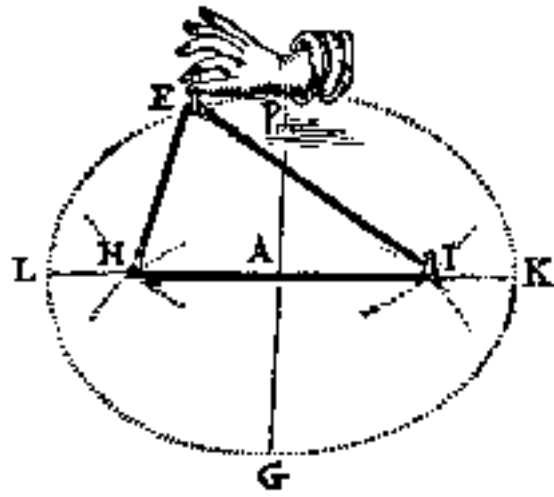

Figure 1

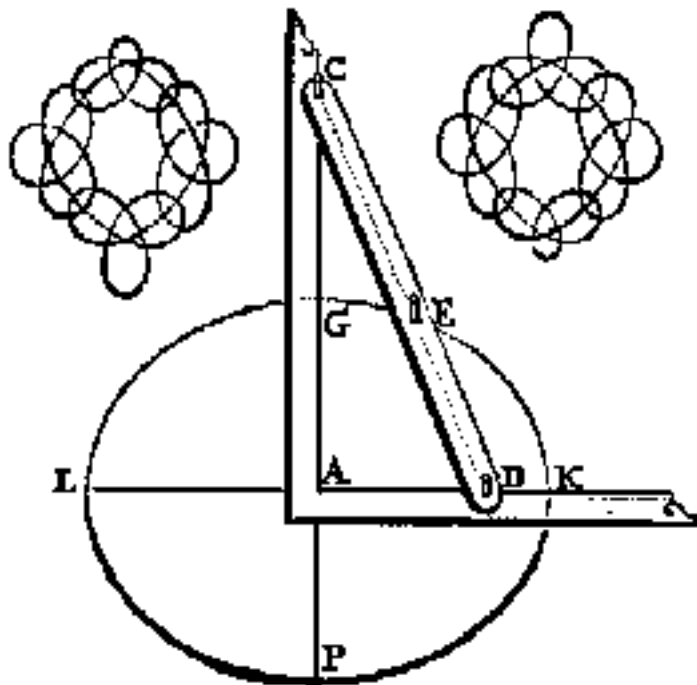

Figure 2

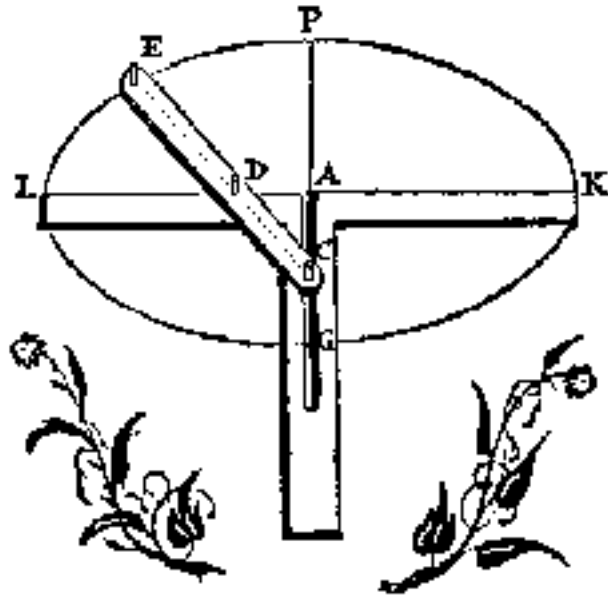

Figure 3

Our string device involves a 3 ft x 4 ft paper-covered sheet of soft plywood into which tacks can be inserted. An adjustable loop of string can then be placed over the tacks and drawn taut with a colored pencil. The string is tough braided nylon that will not stretch, and the length of the loop can be quickly and easily adjusted by a spring-locked slide, such as those found on the drawstrings of coats.

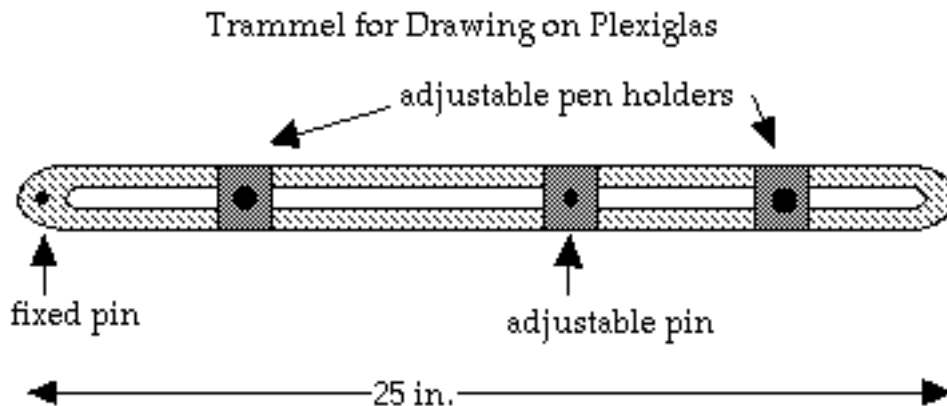

Figure 4

Our trammel device works on a 3 ft x 4 ft sheet of Plexiglas into which two narrow grooves ($1/8$ in) have been carved at right angles to each other and bisecting both dimensions of the sheet. The trammel itself (see Figure 4) is made from a 25 in slotted wooden stick with a fixed pin at one end that can slide in one of the grooves in the Plexiglas. An identical pin, which can slide in the other groove, protrudes from a

small aluminum holder that fitted into the slotted stick and can be locked with a thumbscrew at any chosen distance from the fixed pin (range: 2 in to 25 in), thus creating a trammel of adjustable length. The path of motion of any point on the trammel can be traced on the Plexiglas by a pen fitted in one of the adjustable penholders. Aluminum pieces, drilled as penholders for dry-erase colored marking pens are fitted into the slot of the trammel. These penholders can be locked at any position on the trammel with a thumbscrew. The pen fits tightly into the penholder and does not need to be held by hand during the drawing motion of the trammel. One penholder is placed between the two pins to form a trammel device as in Figure 2, and the other is beyond the second pin for drawing curves as in Figure 3.

We choose to build these two particular devices for use in student interviews for the following reasons. Ellipses are common in visual experience, science, and art, are aesthetically pleasing, and although the curve is not the graph of a function in a narrow sense, it has an equation that is fairly simple and familiar to students. These devices are all relatively simple to build, demonstrate, and experiment with. The actions involved in them can be felt directly and intuitively, and although either device can be used to draw the entire family of ellipses, they feel quite different and the adjustments for changing the elliptic parameters work in quite different ways; hence any algebraic relations that emerge directly from the actions will, at first, have different forms. There is an immediate physical element of surprise when such different actions produce curves that look the same. As the interviews will show, this first impression provides a strong motivation for the student to search for a coordination of his physical experience with symbolic mathematical representation.

The high school student being interviewed has heard about the loop-of-string device and has seen his teacher derive an elliptic equation from the constant sum of the two focal distances implied by action of the device. Although the student has not personally experimented with such a device and, hence, has little practical instinct for exactly how variations in the length of the loop and the distance between the tacks will affect the curve, this device provides the student an initial sense of familiarity. The student has never seen a trammel device used to draw curves. Making connections between the loop-of-string and the trammel provides a rich problem-solving experience grounded in an immediately tangible situation. No matter how this situation is approached, it involves some kind of geometrical or algebraic transformation because the former device starts by establishing the foci whereas the latter device starts by establishing the lengths of the axes while giving no immediate indication as to focal position. Algebraic representation of the loop-of-string device tends to utilize the distance formula, whereas the trammel lends itself more towards similarity and proportion.

The subject of these interviews ("Jim") is a senior chosen from a class of New York State Regents' Course Four Mathematics at Ithaca High School in Ithaca, New York in the Spring of 1994. The student was not chosen for any special background or ability. Course Four Mathematics in New York State is a high-school precalculus course taken by seniors as part of the regular Regents' sequence beginning in ninth grade with Course One. Roughly half the students at Ithaca High School will eventually take Course Four Mathematics.

Several students were interviewed concerning a variety of curve-drawing devices, but what we present here focuses only on Jim and his work with the two devices described above. Several times during the interviews, Jim describes himself laughingly as a "terrible student" and said that if his teacher "saw these videotapes he would probably be horribly embarrassed." Jim's teacher describes him as a fair-to-average student who has to struggle hard to keep up with his work. Jim's teacher also finds him to be very helpful and cooperative in class. He is a very open, friendly and talkative person which makes it easy to interview him. He talks almost constantly about what he is doing and thinking, with little or no prodding. He seems to have no inhibitions about being videotaped.

Two individual interviews, about two hours each were videotaped. The second interview occurred one week after the first. Jim was asked not to discuss the project with others until after the completion of all of the interviews. During the week between his two interviews, although he did not have the devices, he was free to work by himself on any unresolved questions and consult any mathematical source material that he thought might be helpful. Jim was not provided with any references or background material until after the completion of the interviews.

The interviews were structured around the following questions:

- (1) Are these devices capable of drawing the same curves?
- (2) Is there any curve which one device can draw but which the other cannot?
- (3) How exactly do you go about setting up one device so as to reproduce a curve drawn by the other device?
- (4) Is there any way to find an equation of a curve directly from the actions involved in the device used to draw that curve?
- (5) What convinces you of your claims and how would you go about justifying them?

Jim expresses a strong preference for geometry over algebra, and most of all he likes physical experimentation. He says that he really enjoys "fooling around with stuff" and wishes that there could be far more geometry discussed in high school. Jim obviously enjoys experimenting with the curve-drawing devices, and rapidly generates

and rejects a whole series of conjectures about how they might relate to each other. Although many of his guesses seem, at first, a bit wild and random, the interviews show that his overall pattern of refining his experiments displays an astute sense of geometric proportion and invariance. He voices many guesses based on things that are visually and physically suggestive to him.

Jim openly admits that he easily gets lost in algebra, and that he finds it very boring. He says that he wishes that his algebra skills were better, and he thinks that this is something he will "have to work on." During his second interview, Jim eventually expresses algebraically the proportions that he has found from the geometry of the trammel device, but when asked if these equations are equivalent to the one that he writes from the loop-of-string device, he pales at the thought of having to attempt an algebraic reduction. His usual cheerful demeanor seems to darken abruptly. When told that he does not have to do this and reminded that he is free to end the interview whenever he wishes, Jim says that it will give him some real satisfaction to see the algebra "come out." He asks the interviewer to watch his algebra carefully because he knows that he will make mistakes. Sometimes he even predicts in advance exactly what type of algebra mistakes he is prone to make, and then several minutes later confirms his predictions.

Jim is asked how important it is for him to see the algebra "come out" in order to believe that the devices are drawing the same curves. He replies (See 3G) that he has made a big jump in his belief, based upon his procedures for reproducing the curves visually, and that the algebraic confirmation is just one more little step. He gestures geometrically with his hands, showing the big jump and the little step. He then estimates the proportions in his gesture at around 8:2 and laughs. Jim has very little confidence in his own algebraic skills, and this seems to transfer over to his confidence about algebra in general, yet he still wants to see the algebra confirm what he has learned from his physical experiments. When he gets frustrated, he directly asks the interviewer for some algebraic advice and was offered a few procedural hints (e.g., "Try squaring both sides"). Once he has corrected and completed his algebra, he has no trouble at all in interpreting these results in terms of the physical reality of the curve-drawing devices, because (as we shall show) that is the primary source of his beliefs.

Part 3 - Jim's Interviews

In Part 3 we will give a general description of the major cognitive steps that Jim made during his encounters with two curve-drawing devices. We broadly classify Jim's investigations into the following seven stages listed in the order in which they occurred:

- A) Physical exploration of the loop-of-string device and its inherent control parameters.
- B) Physical exploration of the trammel device and its inherent control parameters.
- C) Development of a systematic method for trammel duplication of curves first drawn with the loop-of-string device.
- D) Representation of the action of the loop-of-string device with an algebraic equation.
- E) Development of a systematic method for loop-of-string duplication of curves first drawn with the trammel device.
- F) Representation of the action of the trammel device with an algebraic equation.
- G) Epistemic statements concerning the relations between physical geometry and algebraic representation.

The first three stages of investigations take place during the first interview and the last four take place a week later during the second interview. Contained in the Appendix is a more complete and detailed description of Jim's two interviews with extensive transcriptions that illuminate his cognitive process. The Appendix is divided into sections (A-G) that correspond to the seven stages listed above.

3A - Exploration of the loop-of-string

Jim begins by drawing some curves with the loop-of-string device and experimenting with the various possibilities that the device allows. Although he is familiar from his mathematics class with the concept of drawing ellipses in this way, he has never personally used such a device to draw curves. He quickly becomes aware that two parameters are involved in this device, those being the distance between the two tacks and the length of the loop of string. Jim confirms his expectation that the device will produce ellipses and then states that with a fixed loop of string one can obtain "more eccentric" ellipses by moving the tacks further apart. His concept of eccentricity is based on a visual geometric sense of curves being stretched away from a circle and although he remembers that there is some way to numerically measure eccentricity he cannot remember how that is done.

Jim is not entirely sure that this device will draw only ellipses. He experiments and then begins to pull at the string in various ways and then wants to try using a third tack in an attempt to use the loop of string to draw a hyperbolic curve. The interviewer asks him to restrict his attention for the moment to what can happen using a loop of string placed over only two tacks. Jim's experiments produce only ellipses and he hesitantly decides that those might be the only the curves that he can produce in this way.

J¹: I don't really see how you could draw a hyperbola from this arrangement. Maybe you can . . . I'm just probably not looking . . . I don't see it.

Jim is then asked about how the action of the loop of string device might lead to equations of the curves being drawn. Jim says that he has seen this done in his class but he cannot remember how to reconstruct such an algebraic equation. He is however convinced from his physical experiments that the loop of string holds the "perimeter" of a shifting triangle fixed and that this fixed perimeter along with the fixed distance between the two tacks will completely determine any equation of the curve.

D: Would those two measurements be enough to determine an equation or would you need more information?

J: It seems to me that that should be enough, because all that we're using are these two things . . . By varying these two distances we can vary the shape of these drawings, so as far as writing an equation, I would think that these two distances would be the only pertinent information . . . yeah, I'm pretty certain, because it seems those are the only two things that are interacting on this system right now.

We see here how the results of Jim's physical experiments form the foundation of his beliefs about what is controlling the shape of the curves that can be drawn. We also see how these beliefs shape his expectations about the possible form of any algebraic representation of those curves. Despite his distaste for algebra Jim will become more and more determined to continue his investigations until his algebraic expressions are reconciled with his geometric experience.

3B - Exploration of the trammel

Jim next turns his attention to the trammel device. Before drawing any curves Jim makes some guesses as to what might result. If the pen is outside the two pins, as in Figure 3, Jim predicts that the device will draw ellipses. This belief is based on his physical experience with a desktop toy that he owns with a similar motion. When the pen is placed between the pins Jim's first prediction is that the device will produce a cusped star as in Figure 5. Jim is bit surprised to find that both positions of the pen in the device draw curves that appear elliptic. He wonders if this device will ever produce another type of curve and after some experiments decides that it will not.

¹ J = Jim

D = David Dennis (interviewer)

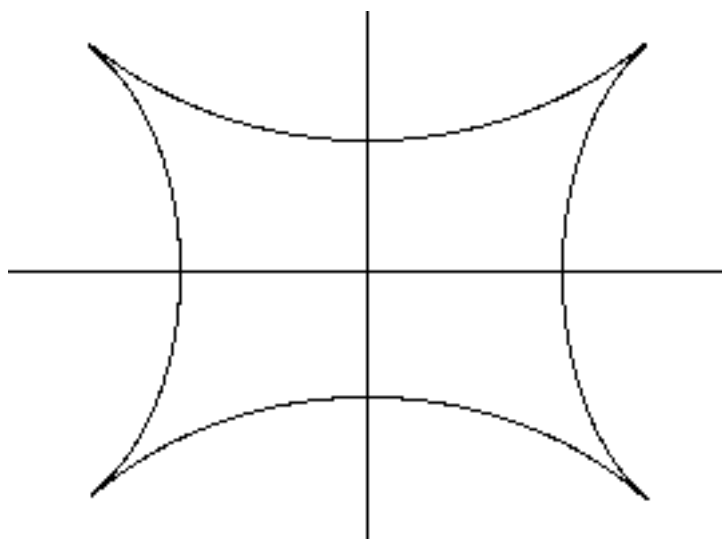

Figure 5

Jim discusses some proportions that he sees in the device that appear to him to be critical to an understanding of its motion. First is the relative rates of motion of the two pins in the tracks. Jim describes qualitatively how when one pin is near the junction of the tracks the rate of motion of the other pin is very small and that hence the motion of the pen is becomes entirely vertical or horizontal depending on which of the tracking pins has the greater rate of motion. Jim describes how the pen's horizontal (or vertical) motion will always be some particular "fraction" of the horizontal (or vertical) tracking pins. This sense of an invariant proportion in the trammel device will stay with Jim and become stronger and stronger until he is able to represent this proportionality in an algebraic form which confirms his physical sense of proportional rates of motion. As we shall see his final algebraic expressions are for Jim not so much a confirmation of the elliptic motion of the device but more a confirmation of the reliability of algebraic expressions to represent physical geometrical action.

Another issue for Jim in his initial trammel explorations is the question of how to get the device to "blow up" a curve, i.e., to create a similar but larger version of a given curve. In particular Jim is concerned with finding situations where the trammel will draw circles. He first looks at cases where the pins are very close together and the drawing pen is outside the pins as far away as possible. These look quite circular and he sees these curves as corresponding to the curves drawn with a large loop of string and two tacks very close together. He does not at first notice that placing the pen at the midpoint between the two pins will produce a circle. When he later discovers this it will be crucial to his seeing how to systematically duplicate the loop-drawn curves with the trammel (see 3C, and Appendix C). Jim has a clear physical concept of enlargement and dilation which guides much of his latter investigations.

3C - Duplication of loop-drawn curves with the trammel device

One main focus of this investigation was to create an environment where curve-drawing actions could be coordinated prior to any algebraic representation. To this end, Jim is asked to try to duplicate with the trammel any specific curve drawn with the loop of string and vice versa. He is asked to be as specific as possible about any system of procedures that he might use to accomplish this task in general.

Jim's initial experiments have convinced him that these devices should be able to produce some curves that are the same. He begins by choosing a specific size loop of string and tack distance (both measured in even inches) and then trying to duplicate this curve with the trammel. His first attempt is to match the distance between the pins with the tack distance and then to set the penholder at a distance that matches half the length of the loop of string. Several times Jim refers to the pins on the trammel as "foci" even though they move during the drawing of the curve. Jim is committed to some correspondence of this type because of his observation that the trammel draws curves that are quite circular when the pins are close together and the pen is far away from them. He sees this as analogous to a large loop of string and two closely spaced tacks.

After various adjustments to this scheme Jim is unable to duplicate the loop-drawn curve although he does draw a curve which he feels might be a "blow up" of that curve. He then begins experimenting with trammel setups where the pen is between the two pins. Trying to match various measurements from the loop-of-string arrangement to the trammel, Jim eventually sets with the pen halfway between the two pins. Before he begins drawing the curve he exclaims:

J: Oh! . . . This is obviously going to be like a circle. I should have seen this before.

Jim draws the curve and gets what he expects and then explains how the distances of the pins from the pen holder determine where the curve will cross the horizontal and vertical tracks, which he now calls the x and y axes. In this case those two distances are both equal, and he says that is "a characteristic of a circle." This is an important moment for Jim because he realizes that axis lengths rather than focal distance are inherent in the setup of trammel device.

J: This is pretty much as close as we're going to get to a perfect circle. That's my prediction.

D: Do you think that this is a perfect circle? Or as close as you can get with this device?

J: Theoretically, yeah, it probably is a perfect circle, because this distance here and this distance here [indicates the half axes] are supposed to be exactly the same . . . It looks circular to me.

Jim continues experimenting with the trammel device and eventually sees that the distances of the pen from the pins will have to match the half axes on the loop-drawn

curve. He can see immediately the length of the semi-major axis of the loop-drawn curve. He then looks for the length of the semi-minor axis on the loop-drawn curve. After some initial mismeasurments Jim accurately reproduces the curve using the trammel by using the semi-major and semi-minor axes as the distances from the pen to each of the pins.

J: Looks reasonably close.

D: Do you have a system at this point for copying any curve over there [string loop] with this thing here [trammel]?

J: I should be able to.

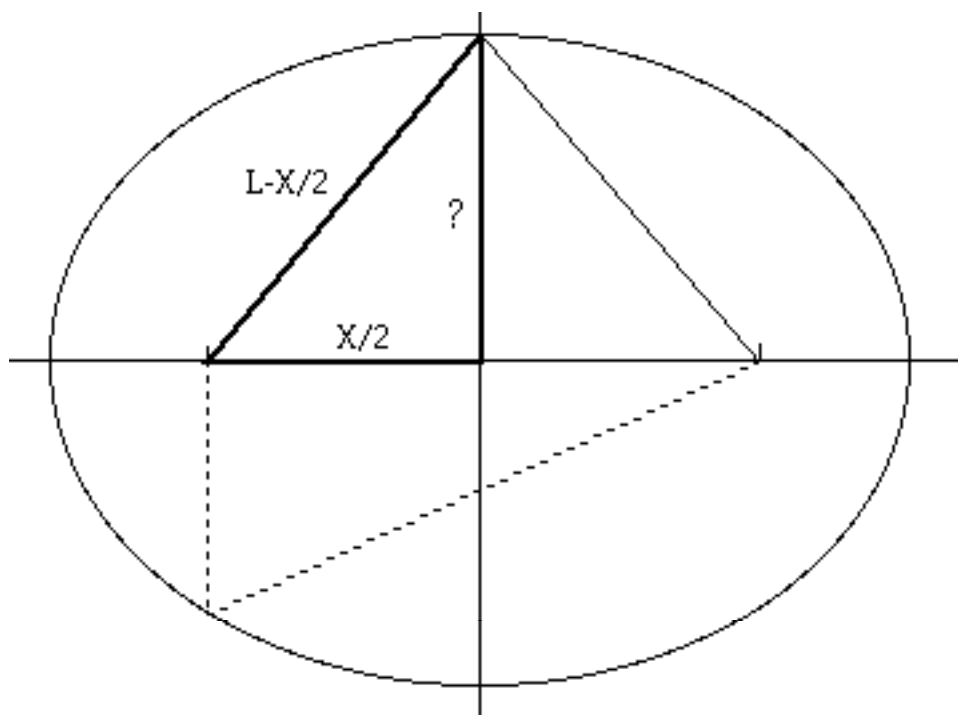

Figure 6

Jim explains how he will use the midpoint between the tacks as a "center" or "origin" and that he will measure the half axes, then set up the trammel accordingly. I then ask him if he can calculate these trammel settings from the tack distance and the length of the loop of string. He tells me that the semi-major axis is " $L - \frac{1}{2} X$ " (where $L =$ half the loop, and $X =$ Dist. between the tacks, see Figure 6). Jim then explains that by dividing in half the isosceles triangle formed by the loop of string set at the end of the minor axis, he will get two equal right triangles each having a hypotenuse of $L - \frac{1}{2} X$, and a leg of $\frac{1}{2} X$. Using the Pythagorean theorem he can then find the semi-minor axis that he needs to set up the trammel.

Through personal physical experience with curve-drawing devices, Jim has come to several important realizations in his first interview. He sees that radically different mechanical actions with very different relative rates of motion can trace the same overall curves. At first Jim expects to find a way to set up the focal distance on the trammel because that is how the loop-of-string device worked. He then sees that the parameters of control inherent in different devices can be different. The realization that the trammel device gives direct control over the lengths of the axes eventually will lead Jim to a very different approach when he comes to an algebraic analysis of the trammel device. Similarity and invariant proportionality will play a much more central role in his vision of the trammel's action, and he will eventually see how his vision can be directly translated into an algebraic equation that both confirms and validates his physical and geometrical beliefs. His eventual algebraic confirmation of his well-grounded physical beliefs will provide Jim with a much more profound belief in the possibility of mathematics to allow for consistency across multiple representations.

Second Interview

3D - An equation from the loop-of-string device

When Jim returns a week later for his second interview, he begins by telling me that he has looked over some of his notes on conic sections, and that he has thought about what is "important" in the loop-of-string device. He puts two tacks in the board, and says that the distance between them is "important." He then uses the loop of string to draw an ellipse and chooses a point on the curve and labels it (x, y) . After some discussion of the symmetries of the ellipse, Jim explains precisely how the parameters that control the loop of string device can be used to write an equation of the curve drawn by the device. His explanation differs somewhat from the exposition given in his textbook in that he makes far more direct appeal to the physical possibilities of the device (See Appendix D). After defining the constants a , and c on the device (See Figure 7), Jim writes the equation of the curve as:

$$\sqrt{(x+c)^2 + y^2} + \sqrt{(x-c)^2 + y^2} = 2a$$

He then states that this equation can be algebraically reduced to: $\frac{x^2}{a^2} + \frac{y^2}{a^2-c^2} = 1$.

He has seen his teacher make this reduction, and he feels that he could probably reproduce it, but that does not interest him.

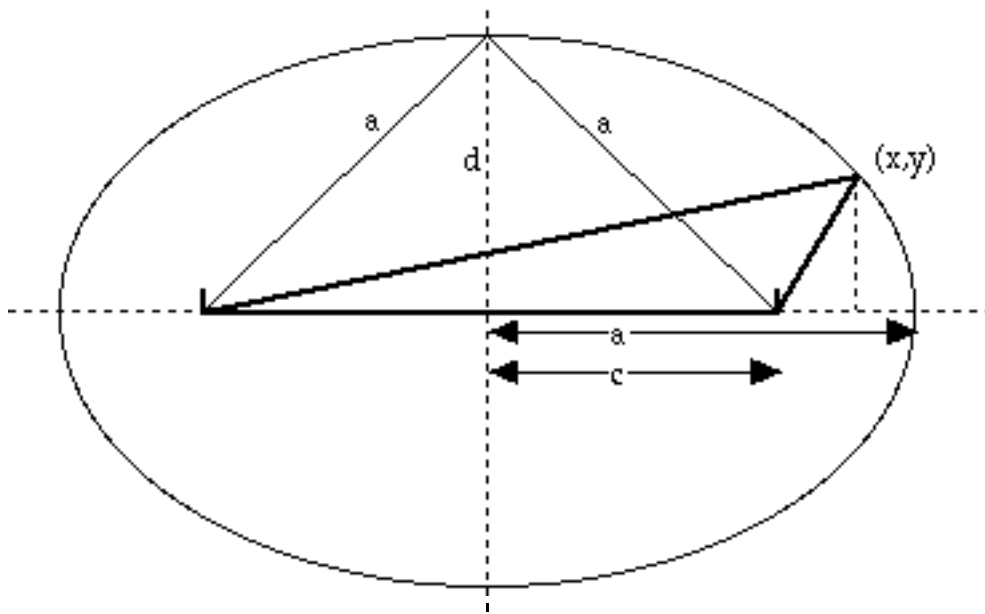

Figure 7

3E - Duplication of trammel drawn curves with the loop of string device

Jim is quite convinced at this point that the two devices draw the same set of curves. He is then asked how he would go about setting up the loop-of-string device so as to copy a curve first drawn by the trammel device. This is the reverse of the duplication method that he developed during the first interview. After reviewing that method he proceeds by labeling the semi-minor axis as d and observing that $d^2 + c^2 = a^2$. Jim clearly demonstrates that a and d are the parameters that are inherent in the setup of the trammel, while a and c are the parameters that are inherent in the setup of the loop of string. He now faces the problem of how to determine the focal distance (tack distance) from a given trammel setup.

Jim sees that he can use the Pythagorean relationship between a , c , and d to calculate c and then use a and c to setup the loop-of-string device. He tries this and is reasonably satisfied with the results of this first duplication, but he continues searching for more compelling evidence that the curves being produced are actually the same. He returns for a while to his claim that placing the trammel pen halfway between the two pins will draw a circle.

While examining various aspects of the motion of the trammel, Jim discovers a second way to find the foci of any trammel drawn curve. This method involves using the trammel itself as a compass. After using the trammel to draw an ellipse with axes a and d , Jim takes the trammel out of the tracks places one pin at the top of the semi-minor axis and then swings the pen in an arc of radius a and marks the places where this arc intersects the major axis (See Figure 8). Since a and d are the lengths on the trammel this involves no readjustment of the trammel settings. The pen in the trammel works quite

well as a compass and this direct physical method locates the foci accurately without any calculation or numerical measurement. With the help of the interviewer, Jim holds tacks on the marked foci and places the loop of string on the Plexiglas sheet and physically traces over the curve that he has just drawn with the trammel. The trace very accurately matches the trammel drawn curve. This is yet another example of how Jim ingeniously uses the physical geometry of his tools to accurately accomplish tasks without the use of algebraic notation or calculation.

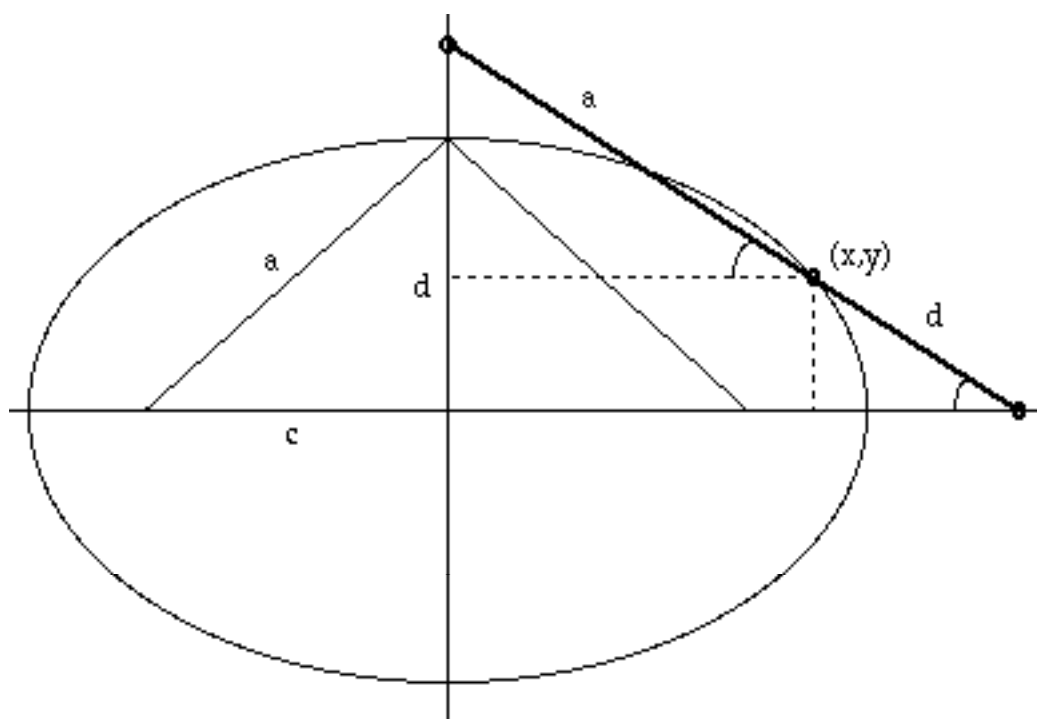

Figure 8

3F - An equation from the trammel device

D: Is there any other kind of argument that could really nail this down?

J: Well I'm guessing that the equation is going to be the same for both, since we have the equivalent pieces.

D: Is there a way to get an equation out of this device [the trammel] that talks about the geometry of this device?

Jim carefully studies the motion of the trammel over one quarter of the curve. He watches as the trammel moves towards its vertical position and observes that the pen and the pin move towards the vertical track "in constant ratio." He labels the pen as (x, y) and draws two dotted lines on the Plexiglas (See Figure 8). Jim observes that the two right triangles with hypotenuses a and d are always similar for any trammel position. He discusses this idea in various ways and says that this "constant ratio" is what he sees as the most essential feature of the trammel's motion (See Appendix F).

Jim is not at all sure how to express this idea in an algebraic statement. He spends quite a while physically pointing to lengths that he knows are proportional using phrases like "this distance here" or "the base of that triangle." Jim paces around and looks at the figure and the curve from various perspectives. He takes off his glasses and appears deep in thought. He mutters repeatedly about points that move "in a fixed ratio." Eventually Jim copies his drawing onto a sheet of paper and begins labeling the lengths in the similar triangles (See Figure 9). It takes a while before he puts in the two square root expressions.

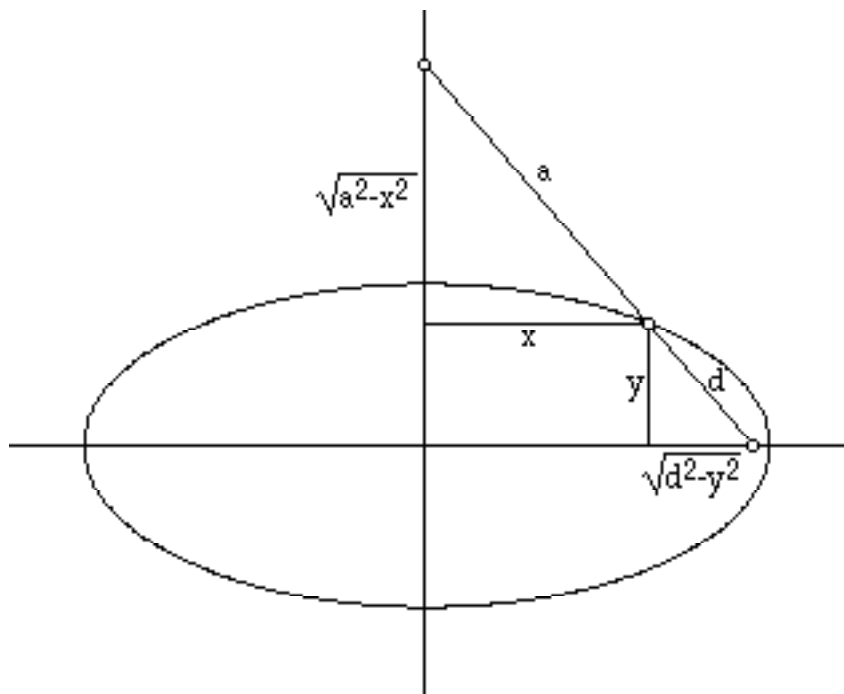

Figure 9

Eventually Jim writes down a proportion from his figure as: $\frac{a}{d} = \frac{x}{\sqrt{d^2 - y^2}}$

D: Is that an equation for this curve?

J: I don't know.

D: Looks like an equation.

J: It's an equation that's for sure [laughs] . . . but what's it saying . . . It's giving you . . . uhhhh . . . I don't see why not. I mean it's giving you this distance x and y , given an a and a d , which we can get from those things [points at trammel].

D: OK, so it's an equation that talks about this curve. Is it the same equation that we got over there with that string device? Is this equation equivalent to those two over there, or is it different?

J: It's got the same look to it as far as the ratios go . . . things like that . . . you know . . . the relation of the . . . but the thing is that there are no squares besides down here

[indicates y^2 under the radical but no square on x , or a]. Whereas on the other side over there [indicates: $\frac{x^2}{a^2} + \frac{y^2}{a^2-c^2} = 1$, from loop of string] there are no square roots, there are just squared numbers.

Jim is hesitant to believe that this can be an equation for this curve, because it looks very different from the reduced elliptic equation that he knows, and because it has been too easy to obtain [he says this later]. He is expecting some complicated use of the distance formula as he has seen in class for the loop of string. Using a proportion from similar triangles seems too easy to him. Jim is also very hesitant to perform any kind of algebraic manipulation. He says he is very "bad at algebra," and the thought of having to do it makes him very anxious. He mutters to himself with a foreboding tone "here come the rules." He stares at his new equation for while trying to decide what to do.

With a procedural hint from the interviewer (i.e., "Square both sides"), Jim's final derivation slowly proceeds as follows:

$$\frac{a}{d} = \frac{x}{\sqrt{d^2-y^2}}$$

$$dx = a \sqrt{d^2-y^2}$$

$$\frac{d^2x^2}{a^2} = d^2 - y^2$$

$$\frac{x^2}{a^2} = \frac{d^2 - y^2}{d^2} = \frac{d^2}{d^2} - \frac{y^2}{d^2}$$

$$\frac{x^2}{a^2} + \frac{y^2}{d^2} = 1$$

Jim knows what he is trying to do. Once the radical is gone he immediately tries to obtain the term x^2/a^2 , because it appeared in the other equation. Once he has that, he continues on and is pleased when the equation eventually

appears as: $\frac{x^2}{a^2} + \frac{y^2}{d^2} = 1$. He looks over at the loop-of-string equation

[i.e. $\frac{x^2}{a^2} + \frac{y^2}{a^2-c^2} = 1$] and smiles. When asked about the difference between the two equations, Jim knows immediately that d^2 and a^2-c^2 are the same. That, after all, is the geometric relation that he demonstrated so well when using the trammel as a compass.

J: I'm happy.

3G - Jim 's epistemology

After verifying that the same equation could be derived from the two different devices, Jim discussed the sources of his beliefs and his views on the relations between geometry and algebra. For him the algebraic equations are not so much a proof that the curves are the same, but more a demonstration that the algebraic representation of curves is consistent with physical geometric experience.

D: Does this convince you that the curves are same?

J: [with resignation] Well, if they have the same equation, I guess I should be convinced.

D: But equations, deep down, don't seem to convince you very much. Is that what you're trying to tell me? Do I detect a skeptical note?

J: No, I'm happy. I mean seeing the equation the same makes me happy, but I was more convinced the first time I saw the similar . . . uhh . . . graph . . . or drawing . . . or whatever you want to call it . . . Well, I can't say I was more convinced . . . I was quite certain . . . I mean I took a large step when I saw the relationship between the drawing tool we had here [trammel] and the string over here, and getting those two to draw the same thing; I immediately thought, OK, they're doing the same operation. They're making the same kind of picture. Therefore, they're doing the same thing. They're operating in the same way. And they probably do have a similar equation. And getting that equation to work out, you know, confirms it . . . but it's not like it's a great shock . . . It's something I already knew . . . You know, I kind of assumed that it was like that.

D: So the physical experience was really a more convincing experience to you than an algebraic experience?

J: Well, not to belittle the power of the algebra to show you, without a doubt that it's like that, but I mean I was relatively certain . . . If you can look at my steps of certainty . . . I took a large step from here to here [gestures about 1 ft on the table] when I first saw it drawn out and I could get it to do the same thing . . . and from here to here [gestures about 2 in] when I saw it [the algebra] . . . well yeah OK . . . This being my total amount of certainty.

D: [laughing] I see... if you had to put it on a one to ten scale? I'm looking at a ratio on your fingers there of ahhh..... looks like maybe...

J: 8 to 2.

D: Eighty percent confident with the experimentation, and the algebra give you another twenty percent on top of that? Something like that?

J: [laughs and nods] Yeah . . . Actually it surprised me that I was able to get it so easily . . . But it worked out nicely. I guess doing it with similar triangles was a good idea. I mean . . . it looked right.

D: That was what jumped out to your eye: these two triangles?

J: Yeah, I mean I saw them. When I approach something I try to draw in everything that I can, so I can get an overall sense of what it's going to look like, and then look at each piece of it with the greatest amount of . . . uhhh . . . greatest degree of . . . uhhh . . . I want to have all the detail . . . So then I can look at the overall thing, and then look at each piece and how it relates to the overall drawing, rather than getting caught up in algebra [voice drops]. Algebra for me, it helps to make something certain and to give it a great deal of shape, but the actual thought of how something's going to work out happens in the geometry.

D: I see. Geometry is somehow more deeply convincing to you?

J: [nods] Also much easier to understand the way that things interact with each other. Watching this piece move along like this [moves trammel along curve], and watching this decrease as this decreases [indicates two horizontal distances, one from the pen to the vertical-axis and the other from the horizontally moving pin to the center], I can see that those are in a fixed ratio from watching this thing move.

Jim here reiterates exactly how he sees two points moving in a "fixed ratio." Even before Jim mentions the pair of similar triangles in Figure 9, his videotaped gestures clearly indicate that he sees pairs of points moving proportionally towards lines. The static figure with the similar triangles does not really convey how Jim experiences and "sees" this invariant relation. Mechanical dynamics is crucial to Jim's understanding of how these curves are being generated.

When Jim arrives at an algebraic equation, he is immediately aware that the equation represents a general ellipse, and that it is consistent with his geometric experiments. Jim's personal confidence about the curves being the same is not based on achieving an algebraic result, but this confirmation of his experiments in another representation enhances both his beliefs about the viability of his geometric methods, and (especially) his beliefs about the ability of algebraic expressions to coordinate with these geometrical methods. He very much wants to see a clear symbolic confirmation of what he already believes. Far more than his beliefs about the curves being the same, the derivation of the equations greatly enhances Jim's confidence in the language of algebra.

J: It makes me feel good to get that!

I have quoted Jim at length here because he so articulately expresses the sources of his beliefs and how they relate to each other. Jim here clearly takes a view of mathematics that was at the heart of scientific revolution of the seventeenth century when one of the main issues was whether algebra could consistently represent kinetic mechanical geometry (Dennis, 1995). I invite the reader to compare Jim's epistemological and psychological statements with some from René Descartes' *Rules for the Direction of the Mind*, written in 1625, about 10 years before he would publish his famous *Geometry*, in which he analyzed many curve-drawing devices.

Rule 13: If we understand a problem perfectly, it should be considered apart from all superfluous concepts, reduced to its simplest form, and divided by enumeration into the smallest possible parts.

Rule 14: The same problem should be understood as relating to the actual extension of bodies and at the same time should be completely represented by diagrams to the imagination, for thus will it be much more distinctly perceived by the intellect.

Rule 15: It is usually helpful, also to draw these diagrams and observe them through the external senses, so that by this means our thought can more easily remain attentive.

René Descartes, (1625 trans. 1961).

Part 4 - Conclusions:

Jim's skills and habits of observation and investigation are unlikely to be engaged by our traditional mathematics curriculum. His ability to play and tinker and hypothesize in a physical setting are not often called for in mathematics classes. Even his refined visual sense of ratio helps him only on few occasions, due to the paucity of physical geometry in our secondary curriculum. What passes for "context" in classrooms is most often sets of "word problems," which may describe a situation but rarely involve designing or physically experiencing a particular "context." Most "contextual problems" in mathematics curriculum are, in fact, decontextualized.

For example, the trammel involves the same action as a ladder sliding down a wall, a common rate problem in calculus; yet few teachers of mathematics know that the motion of any point on that sliding ladder is elliptical. We have asked many experienced calculus teachers this question, and although they were all familiar with the common rate problem, they were all very surprised that the motion of points on ladder was elliptical. The most common first guess was that the motion of points on the sliding ladder was hyperbolic (i.e., something like the graph of $y=1/x$), followed by guesses that it resembled some kind of cusped curve, like Jim's star (Figure 5). Calculus teachers (ourselves included) have taught this "contextual rate problem" for years, without ever physically examining the action involved. Traditional mathematics curricula do not tend to develop strong instincts for motion, although the genesis of calculus was based on such experience (Dennis, 1995). A student like Jim is far more creative and inspired

when given a physical action to control and observe. Jim can clearly see rates and "constant ratios" long before he can express them in algebra. For him, algebra had to emerge from geometrical motion in order to be a viable form of expression. Historical records show that this was also true for many mathematicians, particularly those who were involved in the original creation of analytic geometry and calculus in the first place, e.g., Descartes, van Schooten, Roberval, Pascal, and Newton (Dennis, 1995).

The recent educational reform emphasis on "visualization" is still locked into an epistemic hierarchy where equations create curves, but rarely vice versa. Graphs are mostly seen as secondary facilitators that help one visualize an equation or numerical data (see, for example, any of the many articles in Romberg, Fennema, & Carpenter, 1993). Although such reform efforts contribute many important educational insights, they do not give truly independent status to different representations, and the approach to analytic geometry taken by Descartes and other seventeenth century mathematicians is almost entirely absent. Even most "reformed" curricula fail to complete a cognitive feedback loop where multiple representations, including physical dynamic geometry, are given fully equal status.

Jim shows no strong inclinations towards algebra or traditional functional notation. He is much happier using statements about changing rates and the invariance of ratios that directly expresses his geometric vision. Jim prefers to see the ratios inherent in the dynamic system, and study their operation physically. Although he does not use functional language, his notion of the physical parameters with which one controls and prescribes the motion of a device is astute, and his sense of how an equation "talked about" what was happening with respect to the motion of a device is well expressed.

Many students, like Jim, express a longing to return to geometry, as the piece of mathematics that they most love. I think that some experience, much earlier in the curriculum, with curve-drawing and dynamic geometry would help to inspire them and give voice to their perceptions. In such a context they might find a way to engage more profoundly their gift for seeing ratios. This could go a long way towards changing their attitudes about algebra and mathematics in general. Jim's beliefs were formed mainly by physical and geometric experience as he so directly expresses (80%). For algebra to be meaningful to Jim, it has to be a careful and precise confirmation of what he has physically experienced. We feel that there are many more students like Jim for whom a belief in the viability of algebra would best evolve through coordination of symbolic expression with physical geometric experience.

Although Jim dislikes algebra, the experience of connecting and confirming geometric experience with algebraic expression is both engaging and satisfying. Interviews with Jim point up the need to bring about a more balanced dialogue both

between geometry and algebra and between physical experience and theoretical language. Jim could have benefited greatly from experiences with curve-drawing long before he reached his senior year of high school. Curve-drawing could have been introduced in middle school long before the equations of curves were even mentioned. It could have been connected to many other empirical activities where curves are directly generated (e.g., sundials). Having a base of such grounded activity would have been beneficial in many ways. Although we have presented here only two curve-drawing devices, this approach to curves is quite general in that all algebraic curves can be drawn with mechanical linkages, a theorem that is little known in the United States, even to professional mathematicians (Artobolevskii, 1964; Dennis, 1995).

Such a base might give many students an entirely different feeling about algebra. If they see algebra as a systematic language developed to allow for the expression of his physical and mechanical visions, it is much less likely that they will come to see it as boring and fearsome. Even after having developed some debilitating attitudes, Jim is still able to work clearly and precisely within a problem solving situation where his visual skills were clearly valuable and connected to the problem. He does not want to avoid algebra at all costs. He wants to see how it can express what he sees, and validate what he experiences. By reversing the usual epistemic hierarchy where curves are defined from algebra, the curve-drawing devices give him the stamina to work on a difficult problem. His physical certainty as to what will "come out" gives him the determination to try to confirm his beliefs within an algebraic representation.

If mathematical language is to become comprehensible to a broader audience, it must display early on its capacity for expressing a wide variety of situations. Most often in our curriculum, the linguistic form of mathematics (usually algebra) dictates in advance both the forms of classroom discourse and the allowable span of activities. That is to say that physical activities and "contextual problems" are introduced as examples or applications of pre-established linguistic skills and concepts. The language and symbolisms are not being generated in response to student activity, but vice versa. Because symbolism usually dictates in advance the content of mathematics curriculum, students are only allowed to discuss activities that fit those forms, and often even simple "activities" are only discussed hypothetically and never materially explored. Even more disturbing is the way algebraic simplicity and convenience dictate which curves are admitted for discussion in mathematics classrooms. Algebraic simplicity and mechanical simplicity are not the same. Very simple devices are quite capable of drawing fourth and eighth degree curves (Dennis, 1995). The artificial curtailment of the objects allowed for classroom discussion creates the false sense that algebra is always the best way to go.

Such a situation severely disadvantages students like Jim. Their skills, thoughts, and epistemic inventions remain largely unengaged. Jim does not really hate algebra; what he hates is the way that linguistic rules have come to dominate the content of his mathematics courses. When language flowed from physical experience, Jim is quite ready to push very hard to coordinate and reconcile language with experience. As he says "the thinking happens in geometry." Jim has a vision of what he expects of geometry, but that vision remains out of touch with school mathematics. Jim's vision is largely a seventeenth century mechanical geometric vision, like that of Descartes and Pascal, that involves architecture, civil engineering, and mechanical devices. For example, Jim is disappointed that the geometry that he learns in high school never helps him even to begin to analyze the motion of a mechanical apparatus that resets pins in a bowling alley where he has worked.

Jim clearly benefits from his experience with these curve-drawing devices. His engagement with the curve-drawing devices was profound because they satisfied in him a longing for what he sees as the geometry of the world. We learn a great deal from watching and listening to Jim. Jim's phrase "these move in a fixed ratio" combined with his hand gestures will remain with us. They have already become part of our thinking about the learning and teaching of dynamic geometry.

If our curriculum is allowed to confront the uncertainties and ambiguities of how language interacts with the physical world; if mathematical language, symbols and notations are allowed to grow directly from experiences and be shaped by them, then this fully circular feedback loop could evolve into a powerful epistemological model based upon the coordination of multiple representations. The algebra of equations and functions would then be more than just what Jim despairingly refers to as "the rules." More students would then be able to genuinely say, as Jim does at the end of his derivation, "It makes me feel good to get that."

Appendix - Interviews

This appendix contains detailed descriptions of Jim's interviews with extensive transcriptions. It is presented in the first person from the point of view of the interviewer. The Appendix is divided into sections A-G that correspond to the descriptions in Part 3 A-G.

First Interview

A - Exploration of the loop-of-string device

I began the interview by showing Jim the adjustable loop of string, the two tacks, and the paper-covered board, and demonstrated the action without actually drawing a curve.

D²: Have you ever seen this device before?

J: Something similar, we've sort of covered ellipses in class.

D: So you already have a name for what this draws. [Jim nods]. Would you like to try drawing with this just to see?

J: Sure, I'm expecting an ellipse at least. [Jim draws one complete curve.]

D: Did you get what you expected?

J: Looks like it, yeah.

D: That looks like an ellipse to you?

J: Umm hmm, of course as these [tacks] become farther and farther apart it's going to become more and more eccentric; closer this way [gestures vertically along minor axis] and wider out this way (gestures horizontally along the major axis).

D: OK, would you like to try it one more time?

J: Sure.

D: Go ahead, move it any way you want.

J: [Leaves one tack alone and moves the other one farther away. Draws a new curve using the same size loop of string.] That's the basic idea.

D: You say that you moved the tacks further apart and it became more eccentric?

J: I think so, yeah.

D: Is that what you expected?

J: Yeah.

D: What does "eccentric" mean to you?

J: Well . . . farther away from a circle. I mean if you just had one tack here, say right in the middle [Remove both tacks and places one in the middle and places the loop over

² J = Jim

D = David Dennis (interviewer)

the one tack] I would expect, I think most people would, . . . just to draw the simple circle. [Draws a circle] That's what it looks like to me. As . . . with two tacks, of course I could have used two right next to each other and it would have still looked like a circle even though it wouldn't have been probably, because there's still a slight distance between them . . . what we call focal points in our class (indicates a large loop of about 20 in over two tacks about 1 in apart).

D: OK, call them whatever you feel comfortable with. So if they were close together you say it would still look like a circle but might not actually be one?

J: Yeah, that would be my guess.

D: So "eccentric" to you is something that's farther away from a circle?

J: Yeah, I hope that's not too far from the real meaning, but that's what it means to me.

D: Is eccentricity just a word, or is it associated with anything else? Are there any other thoughts you have about what eccentricity is?

J: Well, from the definition of the word, when you say, someone is eccentric, they're a bit off... away from the norm, which sort of makes sense, cause if something is eccentric (gestures towards ellipse), it's farther away from a circle, which might be a norm because it's relatively stable. But as far as this thing goes, there's a definition that my teacher gave us, and I'm accustomed to using it.

D: Do you remember what that definition is?

J: We had a certain point scale. As eccentricity increased, an object went from a point, to a circle, to an ellipse, to a hyperbola at, I think, eccentricity one.

[Jim describes a video animation of conic sections that he has seen and shows the numeric scale of eccentricity in terms of the visual pictures he has seen. One focal point went to infinity and the remaining visible piece of an ellipse resembled a parabola.]

D: So eccentricity can be a number?

J: Yeah.

D: Is there any way that you could estimate or compute the eccentricity of one the curves that you've drawn here?

J: Probably, yeah if I assigned . . . [begins putting in the tacks to draw a new curve] . . . I'm a terrible student, I don't remember the actual number system, but what we did was ahh . . . it was a basic relation between this length here, and this length here, and this length here [indicates the three sides of a right triangle formed by the loop of string with its right angle at one of the tacks, see Figure 6].

[Jim uses the loop of string to create a right triangle with the right angle at one of the tacks [see the dotted triangle in Figure 6]. He said that he would use the tack at the right angle as the origin of a coordinate system for an equation of the curve, letting the other tack be on the x-axis.]

J: I like to keep things as simple as possible and right triangles are relatively simple. You can use the Pythagorean theorem.

[Jim studies the motion of the string carefully along the curve and begins describing how the distance between the two tacks caused the point on the curve to be pulled in towards "the absolute center" as the point travels away from the end of the major axis. When asked what he means by the "the absolute center" he marks the midpoint between the two tacks and says that it is the center because the curve is "symmetrical through that point." Jim then shows how the distance from the center varied from the end of the major axis to the point where the string forms a right triangle at one tack [not the end of the minor axis]. He says that eccentricity has something to do with the difference in the distances from the center to each of these two points on the curve.]

J: As an object becomes more eccentric, there's going to be a greater difference between these two lines (the segments from the curve points to the center).

[Jim tells me about the eccentricity of ellipses as compared with hyperbolas. When asked if he thinks this device can draw hyperbolas, and he begins experimenting. He pulls at the loop while he traces a curve. He says that he thinks maybe he can do it if he uses a third tack. I asked him for the time being to stick with only two tacks and a fixed loop of string. Jim has a strong inclination to come up with techniques of his own that he can physically investigate.]

J: I don't really see how you could draw a hyperbola from this arrangement. Maybe you can . . . I'm just probably not looking . . . I don't see it.

[I next ask Jim if he knew any way to find an equation of these curves from the action of the loop of string device.]

J: Well we were supposed to know this . . . ahhh . . .

D: What might you try?

[Jim explains that he will first measure the distance between the two tacks, then measure the loop of string when it lies in two equal pieces along the line of the two tacks. He then repositions the loop at another point on the curve and says of the length of the loop that it is, "of course, the perimeter of this triangle."]

J: Then at any point, of course, the perimeter is going to be fixed. Soooo . . . oh how would I do this? . . . [long pause as Jim examines the action of the device along a quarter of the curve]. . . As far as writing a direct equation, I'm drawing a blank here, but I would definitely look at these two lengths here [again places the loop so that it collapses onto the line through the two tacks, and indicates half the loop length and the distance between the two tacks].

D: Would those two measurements be enough to determine an equation or would you need more information?

J: It seems to me that that should be enough, because all that we're using are these two things.

[Jim explains with many gestures and motions of the device along the curve how those two measurements are enough to completely determine the curve in the context of the physical device, so they should also be sufficient to completely determine the equation of the curve being drawn. Although at this point he is unable to write an equation, he is convinced that an algebraic representation will confirm the results of his experiments and that any equation would be dependent on the two parameters with which he can physically control the family of string-drawn ellipses.]

J: By varying these two distances we can vary the shape of these drawings, so as far as writing an equation, I would think that these two distances would be the only pertinent information, because certainly the angles aren't fixed as we slide it around the angles are changing [demonstrates].

[Jim plays with the device some more considering various positions but has no idea how to translate his observations into an equation.]

D: You don't have to do it right now, but you think that you could do it maybe?

J: Yeah, if I thought about it, probably, yeah.

D: You're pretty convinced that that would be enough to get an equation?

J: I hope so! Because that's all I see right now . . . yeah, I'm pretty certain, because it seems those are the only two things that are interacting on this system right now [indicates the two distances, although he seems to have switched from the entire string length to half of it as seen in the collapsed position].

B - Exploration of the trammel device.

I now show Jim the trammel device on the grooved Plexiglas. Before I even move the trammel in the tracks, Jim has a pretty good idea of how it works. He describes a desktop toy known as a "B.S. Grinder" which moves in the same way as the trammel, with a crank attached to a point on the trammel extended beyond the two pins in the tracks, as in Figure 3. His toy cannot be adjusted, and moves in only one curve. I explain how to use the pens and adjust the pins and the pen holders [one between the pins and one outside them]. Jim is anxious to get his hands on the device and draw some curves. Before drawing anything, I ask him what kind of curves he thinks it might produce, and he immediately says that the pin outside of the pin will draw an ellipse. He then speculates on what curves might be traced by the points between the pins [see Figure 5].

Without moving the device Jim then gives a very detailed description of what he thinks will happen when either one of the pins is near the intersection of the two tracks. He explains how, when the pin in the vertical track is near the junction, that both that

pen and the other pin experience almost no horizontal motion and vice versa. He seems anxious to demonstrate what he means, and so I tell him to go ahead and draw a curve. With the pen between the pins, closer to the one in the horizontal track, and the pins about 15 in apart, Jim draws a curve and explains his idea.

He then adds the observation that when the vertical pin is near the junction, the pen is moving vertically "at a fraction" of the pin's motion. His sense of a geometrically determined proportion seems very detailed [See Figures 2 and 3].

J: Say it's moving about an inch in either direction here [vertical pin near junction], this [the horizontal pin] is actually moving in and out a very very small amount, so the pen doesn't move forward and backward very much at all, while it moves up and down . . . oh . . . what is this? [indicates motion of vertical pin] say I have about two inches here. . . It [the pen] is moving at a fraction of that distance here [gestures to indicate a shrinking proportion of vertical motion along the line of the trammel].

[Jim also observes that when one of the pins is near the junction, the motion of the pen is "essentially a line," either horizontal or vertical depending on which pin is near the junction. He expresses these ideas quite clearly using both hands to gesture about relative rates of motion and making "V" gestures with both hands to indicate the proportionality between the motion of the pen and a pin in the track.

Jim next tries to verify his guess that when the pen is outside of the two pins, he will get an ellipse. He wants to make sure that the trammel device works in the same way as his toy, the "B.S. Grinder." He draws a curve using the outside pen holder and is satisfied that his guess is confirmed.]

D: Were you surprised at all by the curve that you got with the pen on the inside?

J: A little bit. I thought it was going to draw a shape more like . . . uhhh . . . [begins to sketch on paper, see Figure 5] . . . I sort of expected . . . or I was hoping that it would do something like this. I'm trying to think now if it's possible to get it to do something like that.

D: Why did you think that? could you explain?

J: Well just immediately looking at this, I was trying to think what would happen when uhhh . . . well you see I hadn't seen the relation that this had with that [begins moving the trammel and pointing to the motion of the inside pen with respect to the pins]. I was imagining . . . I just didn't think . . . but of course this has to stay in that same position, but I was imagining that it would come down somehow [indicates a possible cusp as in Figure 5] . . . I don't know, but I was hoping somehow that it would look like that. It's obvious now that it's not going to do that.

[Jim explains that he now thinks the trammel will draw elliptic shapes in almost any position. This is an excellent example of the powerful and immediate impact that physical tools can have on one's conceptions as well as a classic example of Piaget's

notion of assimilation and accommodation. Jim's vision of the vertical motion of the pen when crossing the horizontal track and its horizontal motion when crossing the vertical track leads him to envision a cusp in the middle where the motion changes. While essentially correct, Jim's theory has to assimilate the experience of the inner pen holder having drawn an ellipse. This leads him to a new theory that accommodates this experience.]

D: Is there any other different shape that you think you could get by putting these [pins and pen holders] in different positions?

J: Well I would expect that I could get a circle if I were to . . . bring these [the pins] very close together . . . or get something that looks sort of like a circle.

[Jim then places the pins as close together as possible [about 2 in] and puts the outside pen holder near the other end of the trammel [about 18 in away]. He begins to trace the motion of outside pen holder.]

J: As it [the pen holder] gets farther and farther out it's going to look less and less like an ellipse, and more and more like a circle [draws large curve and stands up to get an overview] . . . It does look a great deal more circular, although it does look a little bit longer in this direction than it is in this direction, which is what I'd expected.

D: So if we could put these [pins] closer together and the pen further out there . . . that's a way to get something closer to a circle?

J: Yeah, yeah, sure it would look more circular . . . I wonder if it would be more circular? It certainly would look more circular.

[Jim ponders this point and decides to draw some curves just by changing the position of the outside pen holder and keeping the pins as close together as the device will allow. He attempts to make his experiments systematic by referencing his curves to the circle. As he said earlier, the circle functions for him as a basic reference shape or "norm."]

J: What I wanted to see was . . . I wonder if this is any more circular than this is, or if it's just the way we see it [compares large and small "circular" curves by measuring the distance between the curves on the horizontal and on the vertical finding them to be the same]. What I was wondering was . . . if this is just simply a blown-up version of this, or if we somehow changed . . . the uuuh equation of this. I wonder if these equations are same, or if it's just the way we see it. For example if you were to stand two stories up . . . if this [large curve] would look the same as this [small curve].

[Jim decides that just measuring the distance between the curves is not enough to establish whether one is a "blow-up" of the other. He then measures out from the center to both curves on the vertical and again on the horizontal, then uses his calculator to compute the ratios of these pairs of numbers. He gets the ratio of vertical distance out to

the curves: $\frac{15.5 \text{ in}}{4.25 \text{ in}} = 3.64$, and the ratio of horizontal distances: $\frac{17.75 \text{ in}}{6.25 \text{ in}} = 2.84$. He then concludes that these two ratios are not equal, and so the large curve is not a "blow-up" of the smaller one. I asked him which curve is more circular, and he says that the larger one "looked more circular," and that he "wanted to have some way of supporting that observation."]

J: I hope that using a ratio like that is the right way of doing that.

D: Is there any other way to get something more circular with this device?

J: I think we've tried all the different possibilities.

Jim expresses here a very clear conception of geometric similarity, although he does not use the word "similar." Later when looking at triangles Jim uses the word "similar" with precision and comfort. He is very interested in the similarity of these conics, but it seems the word "similar" is used in math classes only for rectilinear figures, and so Jim's use of the word is restricted, despite his clear conception of a "blow up." Apollonius wrote a whole series of propositions for determining when conic sections are similar, and Jim might have been fascinated by such ideas. As his use of ratios demonstrates, Jim is thinking very clearly about the concept of similar curves but has never experienced in mathematics a more general use of the word "similar."

Since Jim has said that the curves drawn by the trammel "looked like ellipses," I next asked him whether he thinks he can duplicate curves drawn by one device with the other.

J: Probably . . . well given this thing's limitations [trammel] . . . You can only get the pins about that far apart [2 in].... You can draw something closer to a perfect circle with that [loop of string] because you can get those [tacks] very close together . . . but if this [adjustable pin] were able to slide in farther I think that they would draw essentially the same things . . . given any combination [indicates adjustments in the devices].

C - Duplication of loop-drawn curves with the trammel device

I next asked Jim to try to duplicate with the trammel any specific curve drawn with the loop of string. Jim begins studying the motion of the trammel in different positions and decides to use specific even numbers of inches. He uses a 26 in loop of string over two tacks 6 in apart. He thinks of this as an ellipse based on a 6 in tack distance and what he calls an "L" of 13 in. He measures the distance from the far tack [focus] to the end of the major axis, or half the total loop of string. Because of his thoughts about circles, he equates the tack distance with the distance between the pins on the trammel; and begins by setting the pins 6 in apart. He then sets the outside pen holder 13 in from the fixed pin to match the setup of the string device and draws the curve.

Just by looking at the curves he decides that they are not the same. He then notices that the trammel is making a curve with 13 inches between the center and the end of one axis, whereas the loop is making a curve with 13 inches between a focus and the end of the major axis. He then decides that he has to measure from the center [halfway between the tacks] which gives him 10 inches. He then resets the pen holder on the trammel at 10 in from the fixed pin leaving the pins 6 in apart. Just by looking at the motion of the newly adjusted trammel, he sees that it is still not going to draw the same curve, because its minor axis is much smaller than the curve drawn by the loop of string. Jim does not measure the minor axes with the ruler but simply uses his eyes. The semi-minor axis of the curve drawn by the loop of string is about 9.5 in while the trammel curve's semi-minor axis is 4 in. Using the outside pen, Jim is still conceptually committed to matching the tack [focal] distance with the pin distance on the trammel. He abandons using the outside pen, without considering a readjustment of the pin distance, which could have achieved the stretch he needs.

D: Did anything improve? Did it get any closer to that curve?

J: We got closer because the distance from this center [intersection of the tracks] to here [end of curve's major axis] should be the same, because I measured 10 inches . . . but I basically need to stretch . . . if I could grab a hold of it and stretch it out in this direction [indicates widening the minor axis of the trammel drawing] . . . Well it looks like it's not going to happen using this outside one [pen holder] so . . . I'll abandon the outside one, and use the inside one [pen holder between the pins] . . . Now rather than going with something completely arbitrary, I'll try 10 [sets the pins 10 in apart] . . . and the six from here to here [sets the inside pen holder 6 in from the fixed pin and draws a new curve]. I don't know if I got closer. Obviously it's going to be a lot smaller, so . . . but it least it's less stretched out this way [gestures that his new curve is rounder than the one previously drawn with the trammel; new curve has half axes of 6 in and 4 in].

[Jim explains that he now has a curve which appears to his eye to be smaller but roughly the same shape as the one drawn using the loop of string. They both appear to him to be "smooth and round." He then thinks about how to increase the size of the one drawn by trammel.]

D: What might you do?

J: Well I was thinking of just . . . uuh . . . basically . . . dilating from this point here [points to fixed pin in the end of the trammel] both these things outward [indicates pen holder and adjustable pin moving farther out the trammel].

[Asked what he meant by the word "dilating," he explains by giving an example where all the distances on the trammel are doubled. He says that doubling is an "easy thing to dilate by," and that it looks as though this will get him closer to what he wants to draw using the trammel. He then sets the pins 20 in apart and the pen holder 12 in

from the fixed pin. He draws a new curve and decides just by eye, that it is not the same curve [half axes of 8 in and 12 in]. Jim then takes the ruler and the trammel and considers new possible settings for the pin and the inside pen holder. Jim tries using lengths of 6, 10, or 13 inches in some way to set up the trammel, because those are the distances that seemed to important when setting up the loop-of-string device. He considers that maybe instead of dilating he should use a "square function," which he describes as doubling one distance while quadrupling another. He believes that the loop of string involved the Pythagorean theorem, which involves squares, so this might make some sense.]

J: You see I was trying to use numbers to be sure that I was getting close to the right thing. . . . It might make sense to try something with squares but before I do that . . . ummm . . . I guess I'm overlooking the obvious, I can get . . . I mean before, I did make something that sort of looked sort of like a circle. It was a much less eccentric looking object, simply by getting the two focal points real close together. [Jim is talking about the pins on the trammel but is calling them "focal points."] So maybe by doing the same thing I can get something close. [Jim returns to considering the outside pen holder of the trammel with the two pins close together]. I didn't really give this a chance.

[Jim plays with this idea by eye, and draws a curve that is fairly close. He tells me that he thinks that by doing this he can get "something that is a blow-up of that one" but that he could never get it exactly because the pins on the trammel cannot be moved close enough together "to get the same scale." He is indeed correct in this observation because the closest setting of the pins is 2 in and in order to reproduce his loop-drawn curves, he would need to have the pins 1.5 in apart. Jim does not, however, express this limitation quantitatively.

[Jim decides to start again, and he erases the Plexiglas and decides to draw a new ellipse with loop of string as well. He leaves the tacks 6 in apart but shortens the loop of string to 24 in or what he calls an "L" of 12 in. He wants to have "L" equal to twice the distance between the tacks. He thinks that this might help him to see how to reproduce the curve. He then decides to try placing the pins 12 in apart, with the inside pen holder 6 in from the fixed pin in order to match the lengths that he saw on the loop of string. He then places the trammel on the tracks, but before he starts drawing the curve]

J: This is going to be six out there and six out there . . . Oh! . . . This is obviously going to be like a circle. I should have seen this before [draws the curve and gets what he expects].

[Jim then explains how the distances of the pins from the pen holder determine where the curve will cross the horizontal and vertical tracks, which he now calls the x and y axes. In this case those two distances are both equal, and he says that is "a

characteristic of a circle." This is an important moment for Jim because he realizes that axis lengths rather than focal distance are inherent in the setup of trammel device.]

J: This is pretty much as close as we're going to get to a perfect circle. That's my prediction.

D: Do you think that this is a perfect circle? Or as close as you can get with this device?

J: Theoretically, yeah, it probably is a perfect circle, because this distance here and this distance here [indicates the half axes] are supposed to be exactly the same . . . It looks circular to me.

[I tell Jim that I can see that the curve crosses the axes at equal distances, but I want to know why the curve remains equidistant from the center at the points in between. He studies the way the trammel moves through one quarter of the curve and then goes back to describing qualitatively the relative rates of horizontal and vertical motion as they vary between the axis crossing points, just as he did in the beginning of the interview. He says that these rates behave just like the sine and cosine functions, and that that is evidence for why the curve is circular. He said that at 45° the rate at which the vertical is increasing is equal to the rate at which the horizontal is decreasing. He cannot be more specific.]

J: The whole reason I think it's a circle is that it's behaving like I would expect a circle to behave.

[I ask Jim to be more specific, and he studies the trammel device some more and then says that the whole device depends on looking at a series of right triangles that all have the same constant hypotenuse, i.e., the trammel. In this case the pins are 12 in apart, and so he says he is looking at the Pythagorean relation $A^2+B^2=C^2$, where C remains constant at 12 in and A and B are the distances of the pins from the center. He then considers the relative rates of change of A and B , because they will be related to the x and y coordinates of the pen moving on the trammel. He thinks it might have something to do with the graphs of the curves $y=1/x$, and $y=1/x^2$. He gets out his graphing calculator and looks at the graphs of these curves and decides these will not help him.]

[Jim next calculates some values for A and B using his Pythagorean relation. He shows me that as B increases from 10 in to 11 in, A decreases from about 7 in to about 5 in, or roughly twice as much change as B , because B is nearing the top at 12 in. I told him that was a good demonstration of his idea about the relative rates, but that in order to convince me that this trammel setting is really drawing a circle he will have to show me that the pen holder stays 6 in from the center at all points along the curve. Jim looks a little flustered, then simply gets the ruler and lays it on the curve, showing me empirically that all points are 6 in from the center. Jim has a triumphant smile on his face, and I feel foolish and pedantic.]

D: OK, you got me on that one.

[I then ask him to return to the task of copying the curve drawn by the loop of string with the trammel. Jim first tries just moving the pen slightly off center, leaving the pins 12 in apart. He thinks this is close in shape but smaller than the other loop drawn curve. He plays with the device some more and eventually sees that the distances of the pen from the pins will have to match the half axes on the other curve. He can see that the semi-major axis of the loop-drawn curve is $12-3 = 9$ in. He then looks for the length of the semi-minor axis on the loop-drawn curve. As in the beginning, Jim pulls the string, so that it makes a right triangle (instead of an isosceles one) with the right angle at one of the tacks. (See the dotted triangle in Figure 6.) He measures the leg of this triangle towards the curve as an axis, getting 8 in (instead of 8.5 in if he had measured out from the center to the apex of the isosceles triangle).

[He sets up the trammel with the pen 9 in from the fixed pin and then moves the other pin 8 in from the pen. He draws the curve, and says that it looks about right, but that he has "no way of really knowing." He then looks back at the loop of string and sees that he has measured the minor axis wrong -- that he should have measured from the center out to the apex of the isosceles triangle. He remeasures and finds the semi-minor axis to be 8.5 in. He makes the adjustment and drew a new curve.]

J: Looks reasonably close.

D: Do you have a system at this point for copying any curve over there [string loop] with this thing here [trammel]?

J: I should be able to.

[Jim explains how he will use the midpoint between the tacks as a "center" or "origin" and that he will measure the half axes, then set up the trammel accordingly, using the distances from the pen to the pins as the half axes. I then ask him if he can calculate these distances from the tack distance and the length of the loop of string. He tells me that the semi-major axis was " $L - \frac{1}{2} X$ " (where $L =$ half the loop, and $X =$ Dist. between the tacks). Jim then explained that by dividing the isosceles triangle formed by the loop when the pen was at the end of the minor axis, he will get two equal right triangles each having a hypotenuse of $L - \frac{1}{2} X$, and a leg of $\frac{1}{2} X$ (see the bold triangle in Figure 6). Using the Pythagorean theorem he can then find the semi-minor axis that he needs to set up the trammel.]

Second Interview

D- An equation from the loop-of-string device

When Jim returns a week later for his second interview, he begins by telling me that he has looked over some of his notes on conic sections, and that he has thought

about what is "important" in the loop-of-string device. He puts two tacks in the board, and says that the distance between them is "important." He then uses the loop of string to draw an ellipse and chooses a point on the curve and labels it (x, y) . I ask him how he measures x and y .

J: Oh . . . Ok . . . yeah . . . a coordinate system . . . let's see . . . I think I'll have the center be . . . [sketches in the axes of the ellipse] . . . You know, . . . so we're going through here with our y and x axes . . . and these [the tacks] are on the x -axis like that.

D: By "center" you mean halfway between the tacks?

J: Yeah, yeah.... and I'm assuming that that's going to be the center of whatever I'm drawing. It's more or less halfway between. That's what it looks like. I think it's easier that way, because then you have the symmetry to deal with rather than having one tack centered on the ahhhh . . . origin.

[Jim explains how he is changing from his original idea of the previous week of using one tack as the origin. He again mentions that he is motivated by the symmetry of the ellipse, so I ask him about that.]

D: What are the symmetries of the ellipse?

J: You've got the definite x and y axis symmetries [indicates his sketch] where you can reflect it over either way.... you can flip it over.

D: And those are the lines you want to use as axes?

J: Yeah . . . It's also got point reflection [indicates center], but that's kind of irrelevant . . . for right now at least. So starting out with a point like this [labeled (x, y)] I was trying to think how you could relate this to . . . whatever it was you were drawing . . . you know, given this, trying to make an equation for it. . . . And so what I thought about was the distance from the origin to these things here [the tacks] and the distance here [marks the distance from the tack out to the end of the major axis].

[Jim looks at the x -coordinate of his labeled point (see Figure 7). He draws in the perpendicular from the point to the major axis. He then decides that he wants to change his previous marked constant to be the "total distance" from the center out to the end of the major axis. He decides to call this a , and labels the distance from the center to the tacks as c and the x -coordinate of his point as b .]

D: Where are x and y in the picture? Can you show me geometrically?

[Jim shows me where they are, and then gets rid of b because he sees that it is "better to call that x ."]

D: What do you want to do with this?

[Jim consults his notes, saying that he "had this all thought out before," but that now he has forgotten some of it.]

J: I decided last time that the basic governing principle . . . the basic things that you needed to have . . . to say, write an equation for this were the length of the loop . . . this

here [pulls string to lie along the x -axis], and the distance between the two focal points [indicates tacks]. I was trying to remember how to write an equation using x and y to create any . . . uuh . . . ellipse [gestures along a piece of the curve].

[When asked about the relationship between the a and c that he has labeled in his picture and those "two basic things" used to draw the curve, i.e., the loop's length and the tack distance, he gestures to show me that c is half the distance between the tacks. He then puts the string back on his general labeled point on the curve and tells me that he is "guessing" that the two string lengths that connected that point to the tacks, "added together would equal $2a$." Jim keeps moving the string back and forth between his labeled point and the end of the major axis where the string triangle collapses onto the x -axis. When asked to explain that to me, he says that it is always equal to $2a$, because if the string all lies along the x -axis he could grab the string at the nearest tack and slide it along like a conveyer belt until the he moves that point to the center. This would amount to a slide of length c . If this is done the point on the string that started at the other tack will also have moved to the center, and the piece of string that is the sum of the distances from the tacks to the curve will now go from the center to end of the major axis and back again, and thus equaling $2a$. Jim expresses this physically by actually marking the string and demonstrating the sliding motion. It is both simple and convincing and avoids the algebraic subtraction that is usually used to show this i.e. $(a-c) + (a+c) = 2a$.

[Jim says that he "didn't need to worry" about the piece of string between the tacks [of length $2c$] because the important part consists of the two pieces that go out from the tacks, and that always adds up to $2a$.]

J: Now where am I going with this . . . uh . . . [consults notes and then returns the string to his labeled point] . . . OK, what I'm trying to do is to get the distance of this one here and this one here [indicates the two string lengths between his point and the tacks], and the easiest way to do that is to use right triangles.

[Jim then sees up right triangles with these two string lengths as hypotenuses and calculates their distances using the Pythagorean theorem (see Figure 7). He clearly indicates the bases of the triangles as $(x+c)$ and $(x-c)$, and their heights as y . He then writes:

$$\sqrt{(x+c)^2 + y^2} + \sqrt{(x-c)^2 + y^2} = 2a$$

Jim's sliding string argument is based on his own physical experience with the device and not on any formula remembered from his classes. He expresses a clear geometrical reason for the constant value of $2a$.]

J: That [the equation] is a really nasty, but meaningful expression for this creation here, whatever we have . . . uhhh . . . given that . . . uhh . . . what we said was that . . . since the string is determining where it [the point on the curve] is going to be, and this [the equation] is telling you the lengths of the string. You're given these points here [tacks]. It [the equation] relates all of the pertinent information together . . . into a nasty equation which . . . you know . . . given higher algebraic skills, I'm sure I could simplify, but I don't really want to . . . unless you're asking me to . . . I know what it is . . .

D: You've been through it before?

J: Yeah, it should be . . . [writes: $\frac{x^2}{a^2} + \frac{y^2}{a^2-c^2} = 1$]. I saw my teacher do it.

[Jim says that he feels he might be able to show that the two equations are algebraically equivalent, but that his algebra skills are not good and that he is "prone to making mistakes when it comes to following rules." I tell Jim that his explanation of the first equation "made perfect sense to me," and that we will just assume for now that the two equations are equivalent without going through the derivation. He says that that "pretty much nailed down" the loop-of-string device, and so he turns his attention to the trammel device.]

E - Duplication of trammel drawn curves with the loop of string device

J: Since these two are equivalent devices, as far as being able to draw the same objects. . .

D: You think they are?

J: I think these are equivalent devices. Experimentally we've been able to draw the same things . . . and . . . given a distance here [loop] I can sort of relate . . . and get a similar looking object over here on this thing [trammel].

[Jim then reviews his method from the previous interview for copying with the trammel device, the curves drawn with the loop-of-string device. He now chooses to call the semi-minor axis d and shows me, by looking at an isosceles triangle formed by the loop of string, that $d^2 + c^2 = a^2$ (from half of the isosceles triangle in Figure 7). He then shows me that using a and d , he can set up the trammel to copy a curve. As an example, he copies his string-drawn ellipse with the trammel.

[I next ask him if he can go the other way and copy, with the loop of string, a curve first drawn by the trammel. Jim is instantly sure that he can, and sets about showing me. He changes the trammel setting arbitrarily and draws a new curve with the pen between the pins. He uses trammel like a compass to mark off the semi-major axis, a , on the string board from a center. Jim then thinks about where to place the tacks.]

J: Well I could work backwards [he marks the half axes on the trammel curve as a and d]. . . [long pause as Jim studies his figures, and marks the length d from the trammel

onto the board] . . . Well I could just do it by trial and error, but I'd rather not . . . I know that it's got to max-out up at this point here [indicates top of minor axis] . . . So since these are going to be an equal distance out [tacks from center] . . . hmmm

D: So what's the piece of information that you need here?

J: I need to know c .

D: OK, you know a , and you know d , and you've got to find c ?

J: ummmmmm.

[Jim then measures a and d precisely in inches from his trammel curve as $a = 8.25$ in and $d = 3.25$ in. He then takes his calculator and begins figuring.]

D: What are you doing?

J: I'm using this equation right here to find c [indicates: $d^2 + c^2 = a^2$] . . . I got an answer of 7.58 in

[Jim then uses the ruler to position the two tacks on a horizontal line each 7.58 in from a marked center. He then adjusts the size of the loop of string, so that when it is placed over the tacks, it reaches out to a point on the horizontal axis 8.25 in from the center. The string loop then goes less than an inch past the tacks on the x -axis. This looks a little tight to Jim.

J: I don't know if it's going to make it. We'll find out . . . But . . . I mean it's close [examines the loops action with his finger]. I don't know if it's a problem with my logic, or if it's something with just the mechanical limitations of the measurements and stuff like that.

D: Well, draw it and see how close it looks. Give it a try. [Jim draws the curve with some difficulty because the string fits so tightly over the tacks.] Does it look reasonably close?

J: It looks reasonably close, yeah. I think . . . I mean given the inaccuracies of the measurements. Hopefully . . . hopefully it's not just a coincidence. I don't think it is . . . because unless I'm not seeing something, the logic follows that it would be the same.

[I tell Jim that his logic convinces me that the lengths of the axes on both curves will be the same, and that this will guarantee that the four points on the axes will match up. I ask him how he can be sure that the other points along the curve are really the same "since the actions that produced the curves were different." I point out that he has shown me in detail that the sum of the distances from the tacks to any point on the loop-of-string device always equals $2a$. I ask Jim if he can give any kind of argument, physical, geometric or algebraic, to show that the points on the two curves are "really the same or perhaps different." Jim readjusts the trammel so that the pen is close to the midpoint between the pins.]

J: Yeah, I was trying to think about something sort of along the same lines. You asked me last time how I could know that something was a circle [points at trammel]. I drew

this . . . [indicates the first trammel drawn curve]; it looks semicircular. And I was trying to think of some argument for that, and I found myself having a difficult time [studies the motion of the trammel along a large close-to-circular curve].

D: Last time you found a way to draw a circle. Do you remember what that was?

J: Yeah, I just have these two of equal lengths [distances from pen to pins]. [Jim uses the ruler to get the two distances the same, at 6 in each. He then draws a new curve which appears circular.] Now the last time that I was working on this I remember trying to talk about the sine and the cosine and the unit circle . . . things like that . . . trying to show the way things were increasing and decreasing at varying rates. And I thought about this for a while, and I couldn't really think of a really conclusive argument to show that it was a circle beyond saying that it's got the same radius here and here [indicates where the curve crosses the tracks]. And sort of looking at it and saying well it's not doing anything special like moving back and forth so there's sort of a fixed ratio between here and here [moves the trammel through on quarter of the curve], and so I'm guessing that it's going to be sort of a constant relation along there, but ahh . . . beyond that I was trying to think of how I could make a good convincing argument . . . Well when we transferred from here to here [trammel to loop device] we said that distance from the first pin to the pen was equivalent to a . Right?

D: unnn huh.

J: And over here when we were drawing this thing [with the loop] we said that $2a$ was constant throughout. The length of the string being $2a$ doesn't change [moves loop of string to demonstrate]. So if this distance here is a [on trammel], and this distance here is $2a$ [length between the pins on the trammel] . . . I'm just trying to get some corresponding pieces from these two different apparatuses. Because they're both doing the same thing in the end, and they have the same sort of measurements, so I might as well call it the same thing. I going to draw myself a little diagram.

[Jim traces a picture of the trammel and labeled the length from one pin to the pen as a . Because he has the trammel set up to draw a circle, he then labels the distance from the pen to the other pin also with an a . I then ask him to review again how in general he transfers curves from the trammel to the loop. He then labels the second distance on the trammel as d and says that in this special case $a = d$. My question was somewhat leading for Jim because, although in a physical sense he has discovered quite clearly how to set up a and d on the trammel, he does not always label things consistently.]

J: Although a and d , in this case, are equal, I should call one a and one d for the purposes of keeping my mind straight. . . . because again maybe . . . uhh . . . I wouldn't have thought of that . . . Now over here [looks at loop of string] . . . I don't know how to put all this together. I'm seeing a lot of different things here. When you label them

appropriately things start to correspond. Obviously when d becomes equal to a over here [trammel diagram] . . . this right triangle [on loop, see Figure 7] goes down to nothing. The two lines [strings] overlap over each other and the two focal points [tacks] have to come together to a point, and that's when you get a circle in this case. Then again over here [trammel], when you're getting a circle is when a and d are equal to each other.

[Jim explains in detail how the right triangle in his loop picture, with sides a , and c , would "collapse" if $a = d$ forcing $c = 0$ which is how he first thought of a circle, i.e., as a curve drawn with the loop over one tack. Jim then takes the trammel and leaves a the same and makes d larger and draws another curve which touches tangent to his circle on the x - axis. He looks unhappy.]

J: I should have made a longer than d for the purposes of keeping everything the same, because now my focal points are on the y -axis [points to where he thinks the foci would be on the Plexiglas and then erases the new curve keeping the circle]. What I want to do is find c on this somewhere, because if I can do that it will show me where the focal points are . . . It's hard to do that with a circle because there is no c .

[Jim readjusts the trammel so that half the vertical axis, d , is equal to the radius of his circle but half the horizontal axis, a , is "a little bit bigger." He then draws a new curve with the trammel that touches tangent to his circle at the two points on the y -axis.]

J: Now I want to find c on this . . . and since c is the base of the triangle formed by d and a . . . and since I said that a is this distance here [Jim lays the trammel on the horizontal axis so that half the axis of the curve and the length on the trammel match up] . . . if I went this like this, then I get the point there... which should be one of the focal points

[Jim takes the trammel and uses it as a compass to draw an arc of radius a from the top of his curve's minor axis intersecting the horizontal axis at his proposed focal points. He then traces the a, d, c triangle on both sides of the vertical axis (see Figure 8).

[I am amazed at his use of the trammel as a compass to find the focal points in this simple and exact physical way. The tool works quite well as a compass. Because the pen distance is already set, all he has to do is hold the pin fixed in the track at the end of the minor axis, take the other pin out of its track, and rotate the trammel stick. This is yet another example of how Jim uses the physical geometry of his tools to accomplish tasks without the use of algebraic notation or calculation.

[After Jim marks the foci on the Plexiglas, I offer to hold the tacks at these points while Jim traces over the trammel-drawn curve using the loop of string. The tracing seems very accurate to Jim (and to me).]

F - An equation from the trammel device

D: Is there any other kind of argument that could really nail this down?

J: Well I'm guessing that the equation is going to be the same for both, since we have the equivalent pieces.

D: Is there a way to get an equation out of this device [the trammel] that talks about the geometry of this device?

J: I'll do the same thing that I did before. I'll take a point here, (x, y) . . . [labels an arbitrary point on the curve in the first quadrant, see Figure 8] . . . And then look at what this thing is doing while it's drawing that point there [places the trammel so that the pen is on his marked point]. I said before that the important piece of information with this machine was the distance from here to here [pin to pin], and then these distances here [pen to each pin] call them d and a [labels Plexiglas as in Figure 8] . . . hmmm . . . Then I started looking at the right triangles . . . Now what describes that action? . . . hmmm . . . let's see. . . given a certain x . . . [draws a vertical line from his point and marks the x -coordinate on the horizontal axis] . . . [long pause as Jim studies both the trammel and the loop of string figure. He then draws a horizontal line from his point to the vertical axis, dotted in Figure 8] . . . What I'm doing is I'm looking at these two similar triangles [points to small upper and lower right triangles with hypotenuses a and d on the trammel, see Figure 8] . . . I think that they're similar.

D: Why do you think they're similar?

J: Well they share . . . ummm . . . [Moves the trammel to watch its action. Seems to be checking to see whether what he is about to say is invariant along the curve.] . . . first of all they share the same angle [marks angles, see Figure 8] . . . Since it's [base of upper triangle] parallel to the x -axis . . . and their hypotenuses are in a constant ratio [points to a and d on the trammel] . . . And I'm guessing that these sides here, and these sides here [other pairs of sides in the upper and lower triangles] . . . are also in constant ratios . . . that's what you mean by similar . . . How to make that clear? . . . unnnn . . . [long pause]

D: Could you write down some of these ratios you're talking about so I could see an example?

J: As far as numbers . . . numerical? . . .

D: Any way . . . just so we have it written down . . . which things are . . . uhh

J: Well I'll have to label these so I can talk about them [indicates similar triangles] . . . well I said that this was d and this was a [hypotenuses] . . . and let's see . . . information . . .

D: You're measuring your coordinates from where?

J: I meant this point here [labeled point (x,y)].

D: That's the point on the curve, but in terms of lengths, just to be real clear, what's x and what's y ?

J: I meant this distance on the x -axis and this distance on the y -axis.

D: So from the center here that's x and that's y . OK.

Jim then decides to clean up the figure by erasing the a, d, c triangle that he has drawn to show the position of the curve's foci. He said that those lines were "distracting him." He has been trying to copy the method of generating an equation that he had done previously with the loop of string, and so he has been thinking it is important to know the foci, but now that he is looking at the similar triangles he finds this focal triangle distracting. I then ask Jim to review what he has told me about the similar triangles that he has mentioned. He points out again the pairs of sides that he thought "would be in constant ratio."

J: I'm forgetting my geometry here, but is Side, Angle, Angle enough for triangle similarity? . . . I can't remember . . . [pause]

D: I'll believe that those triangles are similar.

J: I'm trying to convince myself . . .

D: Well.... you've got right angles.

J: Yeah.

D: And then you told me that these two angles are equal [marked in Figure 8].

J: Should be. Right.

D: Now if they've got two angles the same, what about the third angle?

J: Of course, it's going to be the same. Right. That is a similar triangle. Angle, angle, angle.

D: So, I believe your statement about the constant ratio. I'm just wondering what that has to do with the curve?

This interchange shows the disparity between Jim's confidence in his own precise and accurate observations and his confidence in his ability to apply rules learned in mathematics classes. Even in geometry, there is a gap. This gap is much greater for Jim, in algebraic thinking.

Jim paces around and looks at the figure and the curve from various perspectives. He takes off his glasses and appears deep in thought. He mutters repeatedly about points that move "in a fixed ratio."

J: Often when I'm looking at something I like to move around . . . Sometimes I'm looking at something for such a long time that I kind of forget about . . . you know . . . I miss something obvious . . . [long break. I get Jim a coke and he paces around thinking] . . . Yeah, my problem is that I'm getting stuck in the same . . . uhh. . . because it worked so nicely I think with that setup [loop of string], and I'm trying to think about what the . . . uhhh . . . [pause].

D: Well what do these similar triangles say? You were telling me something's in a to d ?

Jim points at the lengths in the triangles that he knows are proportional, but he flounders around when it comes to giving any of these sides names other than "this distance" or "the base of that triangle." He has now expressed several times, using

gestures and pointing, the proportions in the triangles, but he would not label or name any of the sides other than the hypotenuses which he labels a and d . He tries to express the base of the lower triangle as "something minus x ." He has previously shown me where x and y are in the picture, so I ask him a review question.

D: Are x and y the sides of any of these triangles?

J: x is the base of this one here [the upper triangle]. y will be the side of that one [the lower triangle].

D: Can we write down anything using what we know?

Jim makes a copy of his figure on paper and labels a , d , x , and y [see Figure 9]. He then says that he wants to "declare something new." At first he says he might want to give a name to the distance of the horizontal pin from the center, so that he can then subtract x from it and get a name for the base of the lower triangle. He never declares such a name, but he tells me what he wants to do.

J: Yeah, I'm finding the best way to express that length . . . and then once I get that I can express this here [height of upper triangle], and this here [base of lower triangle] . . . these lengths in these triangles so I can get these triangles all pinned down. I need to get names for all the sides.

I encourage Jim to work on this, and I specifically encourage him to introduce a new variable if he needs one. I said "Why don't you give some of these things names, and maybe we'll find out what they are later," but Jim is very hesitant to add any new algebraic variables to his picture even though he is a little flustered using "this length" and "that distance" all the time. Jim is physically convinced that all you need to know to set up the device and draw a curve is a and d , so he wants to get an equation using only what he sees as relevant. Jim is extremely uncomfortable with the idea of introducing any intermediate or superfluous variables. Algebraic convenience does not suit Jim's purposes, since he has no faith in his algebraic abilities. He finally turns to the lower triangle in Figure 9.

J: Well I can express these sides using . . . just saying . . . since d^2 equals y^2 plus . . . whatever . . . plus . . . uhhh . . . I don't really know what to call it . . . F maybe? . . . uhhh . . . squared . . . [indicates base of lower triangle].

D: OK so call it F , the base the of the little triangle?

J: Yeah . . . oh . . . it's got to be $\sqrt{d^2 - y^2}$.

At this point Jim is off and running. He immediately eliminates the unwanted variable, F , and it is never mentioned again. It only appears once on his worksheet. Right away Jim sees that he can use the Pythagorean theorem on the upper triangle to find its height as $\sqrt{a^2 - x^2}$, and thereby avoid introducing another variable. He tells me again that things are in constant proportion, and so I ask him to clarify. He tells me that

a and d are in the same proportion as " x and that expression there" (i.e., $\sqrt{d^2-y^2}$). I ask him to write it down.

J: You see I don't really know how to express the ratio [long pause].

D: Well, how do you usually write ratios? Do you have any notation or way of writing ratios?

J: Well, you could say something is in a one to two ratio like [writes 1:2]

D: You like to write them with colons?

J: Well, I mean you could say something is in an " a times x " to a " d times $\sqrt{d^2-y^2}$ " [writes: $ax : d\sqrt{d^2-y^2}$, then scratches it out] . . . You see I don't know if I'm going in the right direction here with the ratios. Sure they're similar but . . .

D: Don't ratios give equations in some way, shape, or form?

J: Yeah . . . It's a lot easier to say that a is to x , as d is to $\sqrt{d^2-y^2}$.

Jim writes:
$$\frac{a}{d} = \frac{x}{\sqrt{d^2-y^2}}$$

D: Is that an equation for this curve?

J: I don't know.

D: Looks like an equation.

J: It's an equation that's for sure [laughs] . . . but what's it saying . . . It's giving you . . . uhhhh . . . I don't see why not. I mean it's giving you this distance x and y , given an a and a d , which we can get from those things [points at trammel].

D: OK, so it's an equation that talks about this curve. Is it the same equation that we got over there with that string device? Is this equation equivalent to those two over there, or is it different?

Jim looks very glum at the thought of having to do any algebra.

J: It's got the same look to it as far as the ratios go . . . things like that . . . you know . . . the relation of the . . . but the thing is that there are no squares besides down here [indicates y^2 under the radical but no square on x , or a]. Whereas on the other side over there [indicates: $\frac{x^2}{a^2} + \frac{y^2}{a^2-c^2} = 1$, from loop of string] there are no square roots, there are just squared numbers.

D: Well, play around with it. Maybe it's different?

Jim is hesitant to believe that this can be an equation for this curve, because it looks very different from the reduced elliptic equation that he knows, and because it has been too easy to obtain [he says this later]. He is expecting some complicated use of the distance formula as he has seen in class for the loop of string. Using similarity seemed too easy to him. Jim is also very hesitant to perform any kind of algebraic manipulation. He says he is very "bad at algebra," and the thought of having to do it makes him very

anxious. He mutters to himself with a foreboding tone "here come the rules." He stares at his new equation for while trying to decide what to do.

Jim's every algebraic move is made with trepidation. He repeatedly asks for help. Before each step, he asks me "Is it equivalent to say . . . ?" or "Is it legal to . . . ?" He tends to get lost in his notation for several reasons. He likes using the eraser to make changes to an algebraic expression, rather than writing a new modified equation. When simplifying an expression, he tends to run the writing together without putting in an equal sign. I caution Jim against such practices. In spite of all this, he does not make any gross algebraic errors although he does not know what to do with the radical in his equation [second line below] . When he asks me, I suggest that he will have to "square both sides of his equation." Jim's final derivation proceeds as follows:

$$\frac{a}{d} = \frac{x}{\sqrt{d^2 - y^2}}$$

$$dx = a \sqrt{d^2 - y^2}$$

$$\frac{d^2 x^2}{a^2} = d^2 - y^2$$

$$\frac{x^2}{a^2} = \frac{d^2 - y^2}{d^2} = \frac{d^2}{d^2} - \frac{y^2}{d^2}$$

$$\frac{x^2}{a^2} + \frac{y^2}{d^2} = 1$$

J: I need to work on my rules. I need to get down and do some of this stuff. But I just hate doing it so much that I have neglected it.

Jim knows what he was trying to do. Once the radical is gone he immediately tries to obtain the term x^2/a^2 , because it appeared in the other equation. Once he has that, he continues on and is pleased when the equation eventually

appears as: $\frac{x^2}{a^2} + \frac{y^2}{d^2} = 1$. He looks over at the loop-of-string equation

[i.e. $\frac{x^2}{a^2} + \frac{y^2}{a^2 - c^2} = 1$] and smiles. I ask Jim about the difference between the two

equations, and he knows immediately that d^2 and $a^2 - c^2$ are the same. That, after all, is the geometric relation that he demonstrated so well when using the trammel as a compass.

J: I'm happy.

G - Jim 's epistemology

J: I'm happy.

D: Does this convince you that the curves are same?

J: [with resignation] Well, if they have the same equation, I guess I should be convinced.

D: But equations, deep down, don't seem to convince you very much. Is that what you're trying to tell me? Do I detect a skeptical note?

J: No, I'm happy. I mean seeing the equation the same makes me happy, but I was more convinced the first time I saw the similar . . . uhh . . . graph . . . or drawing . . . or whatever you want to call it . . . Well, I can't say I was more convinced . . . I was quite certain . . . I mean I took a large step when I saw the relationship between the drawing tool we had here [trammel] and the string over here, and getting those two to draw the same thing; I immediately thought, OK, they're doing the same operation. They're making the same kind of picture. Therefore, they're doing the same thing. They're operating in the same way. And they probably do have a similar equation. And getting that equation to work out, you know, confirms it.... but it's not like it's a great shock . . . It's something I already knew . . . You know, I kind of assumed that it was like that.

D: So the physical experience was really a more convincing experience to you than an algebraic experience?

J: Well, not to belittle the power of the algebra to show you, without a doubt that it's like that, but I mean I was relatively certain . . . If you can look at my steps of certainty . . . I took a large step from here to here [gestures about 1 ft on the table] when I first saw it drawn out and I could get it to do the same thing . . . and from here to here [gestures about 2 in] when I saw it [the algebra] . . . well yeah OK . . . This being my total amount of certainty.

D: [laughing] I see... if you had to put it on a one to ten scale? I'm looking at a ratio on your fingers there of ahhh..... looks like maybe...

J: 8 to 2.

D: Eighty percent confident with the experimentation, and the algebra give you another twenty percent on top of that? Something like that?

J: [laughs and nods] Yeah . . . Some people really like the algebra . . . I need to get more familiar with it . . . But it's . . . [shrugs]

D: Well, just looking at this algebra . . . We arrived at this equation [Jim's trammel equation], and here you worked it all out.

J: Right.

D: Over there [two loop of string equations] we skipped some big horrible step that you said is in some book, or that you saw your teacher do. If you had to derive an equation of an ellipse which method would you rather do?

J: I'd definitely rather do that [his trammel equation].

D: You like the similar triangles better?

J: Yeah

D: That was all distance formula, although we had some Pythagoration in here too.

J: Actually it surprised me that I was able to get it so easily. I thought I was going to have to go with something like finding this distance here and this distance here [indicates the distances of the trammel pins from the center], and then subtracting the x 's and getting an idea of what x was. But it worked out nicely. I guess doing it with similar triangles was a good idea. I mean . . . it looked right.

D: That was what jumped out to your eye: these two triangles?

J: Yeah, I mean I saw them. When I approach something I try to draw in everything that I can, so I can get an overall sense of what it's going to look like, and then look at each piece of it with the greatest amount of . . . uhhh . . . greatest degree of . . . uhhh . . . I want to have all the detail, including it. So then I can look at the overall thing, and then look at each piece and how it relates to the overall drawing, rather than getting caught up in algebra [voice drops]. Algebra for me, it helps to make something certain and to give it a great deal of shape, but the actual thought of how something's going to work out happens in the geometry.

D: I see. Geometry is somehow more deeply convincing to you?

J: [nods] Also much easier to understand the way that things interact with each other. Watching this piece move along like this [moves trammel along curve], and watching this decrease as this decreases [indicates two horizontal distances, one from the pen to the vertical-axis and the other from the horizontally moving pin to the center], I can see that those are in a fixed ratio from watching this thing move.

Jim here reiterates exactly how he sees two points moving in a "fixed ratio." Even before Jim mentions the pair of similar triangles in Figure 9, his videotaped gestures clearly indicate that he sees pairs of points moving proportionally towards lines. The static figure with the similar triangles does not really convey how Jim experiences and "sees" this invariant relation. Mechanical dynamics is crucial to Jim's understanding of how these curves are being generated.

D: Which of these devices do you most enjoy drawing with?

J: The string is more convenient. There's less to worry about physically speaking. On a basic level the tacks hold the string nicely while this [trammel] has to slide through slots and things like that. But it's also . . . it's kind of mystical, the way this slides around and draws it like that [makes trammel action gesture], whereas with the string you can definitely see, because there's definitely something holding back the pen. Moving around, you can see the thing moving around in a prescribed ellipse. Whereas with this [the trammel], you're not directly controlling where this thing [the pen] is; you're controlling where it's sliding, and you sort of watch it moving around [shows that when

he draws with the trammel his hand is on the pins rather than on the pen]. I think it's initially a little bit more difficult to understand, but it's more interesting . . . As I said the first time that I saw it I expected it to do something completely different. I expected it to make a sort of a star, you know something with points [see Figure 5]. It's definitely not as intuitive as the string and the tacks. Not just because I'd seen the string and the tacks work before, but because you can definitely see how it's limiting the distance the pen is going to go.

When Jim arrives at an algebraic equation, he is immediately aware that the equation represents a general ellipse, and that it is consistent with his geometric experiments. Jim's personal confidence about the curves being the same is not based on achieving an algebraic result, but this confirmation of his experiments in another representation enhances both his beliefs about the viability of his geometric methods, and (especially) his beliefs about the ability of algebraic expressions to coordinate with these geometrical methods. He very much wants to see a clear symbolic confirmation of what he already believes. Far more than his beliefs about the curves being the same, Jim's confidence in the language of algebra is greatly enhanced.

J: It makes me feel good to get that!

References:

- Artobolevskii, I. I. (1964). *Mechanisms for the Generation of Plane Curves*. New York: Macmillan.
- Confrey, J. (1993). The role of technology in reconceptualizing functions and algebra. In Joanne Rossi Becker and Barbara J. Pence (Eds.), *Proceedings of the Fifteenth Annual Meeting of the North American Chapter of the International Group for the Psychology of Mathematics Education, Pacific Grove, CA, October 17-20*. (Vol. 1 pp. 47-74). San José, CA: The Center for Mathematics and Computer Science Education at San José State University.
- Confrey, J. (1994). A Theory of Intellectual Development. *For the Learning of Mathematics*. Appearing in three parts in consecutive issues: **14**, (3), 2-8; **15**, (1), 38-48; **15**, (2). Vancouver, Canada: FLM Publishing.
- Confrey, J. & Smith, E. (1991). A framework for functions: Prototypes, multiple representations, and transformations. In Robert Underhill & Catherine Brown (Eds.), *Proceedings of the 13th Annual Meeting of PME-NA*, Blacksburg, VA, Oct. 16-19, 1991. (pp. 57-63).
- Dennis, D. (1995). *Historical Perspectives for the Reform of Mathematics Curriculum: Geometric Curve-drawing Devices and their Role in the Transition to an Algebraic Description of Functions*. Unpublished doctoral dissertation, Cornell University, Ithaca, NY.

- Dennis, D. & Confrey, J. (1995). Functions of a curve: Leibniz's original notion of functions and its meaning for the parabola. *The College Mathematics Journal*. **26**, (2), 124-130.
- Descartes, R. (1638/ Trans. 1952). *The Geometry*. (Trans. D.E. Smith & M.L. Latham). LaSalle, Ill. : Open Court.
- Descartes, R. (1625/ Trans. 1961). *Rules for the Direction of the Mind*. (Trans. L. J. Lafleur). New York: Bobbs Merrill.
- Lenoir, T. (1979). Descartes and the geometrization of thought: The methodological background of Descartes' geometry. *Historia Mathematica*, **6**, 355-379.
- Romberg, T. & Fennema, E. & Carpenter, T. (Eds.) (1993). *Integrating Research on the Graphical Representation of Functions*. Hillsdale, N.J.: Lawrence Erlbaum.
- Schooten, Franz van. (1657). *Exercitationum Mathematicorum , Liber IV, Organica Coniccarum Sectionum in Plano Descriptione*. Leiden. (Original edition in the Koch Rare Books Collection, Cornell University, Ithaca, N Y).
- von Glasersfeld, E. (1978). Cybernetics, experience and the concept of self. In M. Oser (Ed.), *Towards a More Human Use of Human Beings* pp. 109 - 122. Boulder, CO: Westview.